

Tilt & Turn Hardware

Tilt first 'R' hinge parts catalogue & fitting instruction

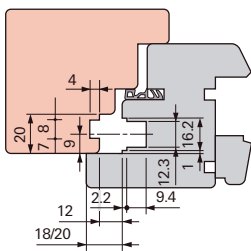

System 12/18-9, 12/20-9, '7/8' Euro-groove



12mm clearance
18/20mm upstand height
9mm hardware axis



System 12/18-9, 12/20-9, 12/18-13, 12/20-13 euro-rebate

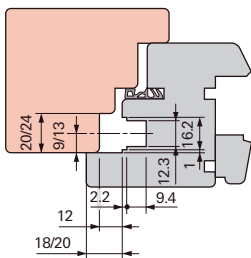

12mm clearance
18/20mm upstand height
9/13mm hardware axis



Important: if using a 13mm axis, increase the rebate to 24mm and position the strikers at the back of the rebate

Facility for adequate drainage should be incorporated in the window design

Product liability and warranty	4
General design description	5
Tilt first security gearing, parts arrangement - 9 & 13mm axis, flat rebate	6
Tilt first security gearing, parts list - 9 & 13mm axis, flat rebate	7
Tilt first security gearing, parts arrangement - 9 & 13mm axis, 7/8 groove	8
Tilt first security gearing, parts list - 9 & 13mm axis, 7/8 groove	9
Tilt first standard gearing, parts arrangement - 9 & 13mm axis, flat rebate	10
Tilt first standard gearing, parts list - 9 & 13mm axis, flat rebate	11
Tilt first standard gearing, parts arrangement - 9 & 13mm axis, 7/8 groove	12
Tilt first standard gearing, parts list - 9 & 13mm axis, 7/8 groove	13
Sash preparation	14
Locking cam options and adjustment	15
Hinging / unhinging the sash	16
Adjustments	17
Maintenance	18
Operating and safety instructions	19

Turn-Only and Tilt & Turn Hardware for windows and balcony doors

According to the defined manufacturer's liability described in paragraph 4 of the "product liability law", the following information regarding Turn-Only and Tilt & Turn Hardware for window and balcony door sashes should be observed. Non-compliance exempts the manufacturer of his liability.

1. Product information and specified application.

Turn-Only and Tilt & Turn Hardware covered by this definition is one-handed operation Turn-Only and Tilt & Turn Hardware for windows and balcony doors in building construction. This is used to enable windows and balcony-door sashes into a turning position by operating a 'hand lever' (handle) or into a limited tilting position in the case of the scissors (sash-stay) version.

Turn-Only and Tilt & Turn Hardware is used on vertically installed windows and balcony- doors made of timber, PVC, aluminium or steel and their corresponding material combinations. Conventional Turn-Only and Tilt & Turn Hardware as covered by this definition, lock window and balcony-door sashes and enable various ventilating positions. When closing, the gasket counter force must be overcome as a rule.

Differing applications do not correspond to its specified application. Burglar-resistant window and balcony doors, window and balcony doors for damp rooms and those for use in environments with aggressive, corrosive air content, require hardware adapted for the respective application and individually agreed upon performance features.

Opened windows and balcony-door sashes achieve only a shielding function and do not meet any demands on joint impermeability, water tightness, sound reduction, heat insulation and burglary resistance.

In the case of wind and draught, the window and balcony-door sashes must be closed and locked. Wind and draught as covered by this definition is present, if a window or balcony door sash while in one of its opening positions, can open or close on its own, in an uncontrolled manner by means of either air pressure or air suction. A static opening position of windows and balcony door sashes can only be achieved with additional hardware.

The resistance against wind loads in a closed and locked state is dependent on the respective designs of windows & balcony doors. Should wind loading in accordance with DIN EN 12210 occur (in particular pressure test p3), suitable hardware compilations are to be matched in relation to the respective window design and frame material, and each case individually agreed upon.

Generally speaking, Turn-Only and Tilt & Turn Hardware can fulfil the demands made for barrier-free dwellings according to DIN 18025. However corresponding hardware compilations and installations for windows and balcony doors are necessary, which must be coordinated and each case individually agreed upon.

2. Misuse

Misuse - therefore not the specified product utilisation - of Tilt & Turn hardware for windows and balcony doors occurs in particular:

- if obstacles are inserted in the opening vicinity between frame and sash, thus preventing its proper specified use.
- when window and balcony door sashes are pressed advertently or uncontrolled (for example by the wind) up against the window reveals, so that the hardware, the frame material or other individual window or balcony-door sash components are damaged or destroyed and/or if consequential damage can arise.
- if additional loads are put on windows or balcony-door sashes (for example if children swing on the window or balcony door sash),
- if while closing the windows and balcony door sashes, someone reaches into the rebate between the sash and frame (injury hazard).

3. Liability

The respective entire hardware set may only consist of hardware components from Roto's outward opening range. In the case of inappropriately assembled hardware, and/or in case of non original accessory components and/or non factory-approved accessory components, no liability is accepted.

4. Product performance

4.1 Maximum sash weights

The following listed maximum sash weights for the individual hardware versions may not be exceeded. The building component with the least permissible load-carrying capacity determines the max. sash weight. Application diagrams and component allocation are to be observed.

4.2 Sash sizes

The presentation of the application diagrams shows the relationships between the permissible sash rebate widths and sash rebate heights, depending on various glass weights and/or thickness'. The resulting sash rebate dimensions or sash formats (portrait and/or landscape format) - as well as the maximum sash weight - must not be exceeded under any circumstances.

4.3 Hardware-combination

The manufacturer's regulations that deal with the combination of hardware are obligatory, (for example: the application of additional stay arms, the hardware design for burglar-resistant window and balcony-door sashes).

5. Product maintenance

Security relevant hardware components are to be examined at least once a year for stability and wear and tear. Depending on the requirements, the fixing-screws are to be tightened and/or parts exchanged. In addition to this, the following maintenance work is to be carried out annually:

- All movable parts and all locking points of the Turn-Only and Tilt & Turn Hardware are to be greased and tested.
- Only cleaning and maintenance agents which do not damage the corrosion protection of the hardware components are to be used.

The hardware adjustments - particularly in the vicinity of the corner pivot rest and the scissors - as well as replacing parts and the unhinging & hinging of the active sash are to be carried out by a specialist company.

When surface treating - for example when painting or varnishing - the windows' and balcony doors hardware is excluded from this process and is also to be protected against any impurities (paint/varnish splashes).

5.1 Retention of the surface quality

Electrolytically applied zinc coatings are not attacked in a normal room climate, when no condensation can form on the hardware or occasionally formed condensation can dry rapidly.

In order to permanently preserve the hardware's surface quality and to avoid deterioration by corrosion, it is imperative to observe the following points:

- The hardware and/or the rebate areas are to be ventilated sufficiently in particular during the building phase so that they are not exposed either to direct wetness or condensation.
- The hardware is to be kept free from deposits and soiling from building materials (building dust, plaster, cement etc.).
- Aggressive vapours in the rebate area (for example: through formic acid or acetic acid, ammonia, amine or ammonia compounds, aldehydes, phenols, tannic acid etc.) in connection with small formations of condensation can lead to fast corrosion of the hardware. In the case of such aggressive vapours occurring, a general adequate ventilation of the rebate areas of windows and balcony doors is to be ensured. This is particularly valid for windows and balcony doors made of oak or other types of timber with a high concentration of (tannic-) acid.
- Furthermore no acetic-acid or cross-linked acidic sealing compounds or those with the above mentioned contents may be used, since both the direct contact with the sealing compound and its vapourisation can attack the surface.
- The hardware may only be cleaned with mild, pH-neutral cleaning agent in diluted form. Under no circumstances may aggressive, acidiferous cleaners or abrasive cleaning agents whose contents are listed in the above paragraph be used.

6. Obligation to issue information and instructions

To fulfil the information and instruction obligations as well as the maintenance operations according to the product liability law, the following is available:

- for planning engineers planning documents for authorised dealers catalogues
- for fabricators installation instructions and factory drawings
- for builders and end users: service and maintenance instructions as well as Operating manuals.

In order to safeguard the function of Turn-Only and Tilt & Turn Hardware for windows and balcony doors:

- Planning engineers are obliged to request and comply with the manufacturers or authorised dealers product information.
- The authorised dealers are obliged to observe and request product information from the manufacturer and to pass this on to the fabricators, in particular installation instructions, factory drawings, service & maintenance instructions as well as operating manuals.
- Fabricators are obliged to observe the product information and in particular to request service & maintenance instructions as well as operating manuals from the manufacturer or authorised dealer, and to pass these on to the builders and end users.

7. Applicability for related hardware

The variations possible within the individual hardware system - for example Tilt-only and Top-hung hardware - are to be treated according to the corresponding valid features of product performance, product maintenance, information and instruction obligations, product information, specified use/application and misuse.

General design description

The general design description lists characteristics of the Roto NT, K hinge, tilt and turn window hardware:

- Designed for use on all timber, PVC-U and aluminium windows with a standard eurogroove.
- Faceplate width 16mm.
- All cams are adjustable by +/-0.8mm, meaning adjustments can be made on site.
- 3 locking cam versions. NT components listed here feature 3 different locking cam options that differ in application and adjusting capabilities.



Locking cam **E**
Compression adjustable



Locking cam **P**
Compression adjustable
security cam



Locking cam **V**
Height and compression
adjustable security cam

- Precision design ensures smooth performance in all applications.

Coating specification

RotoSil surface protection procedure has been developed by Roto for the hardware product range, based upon galvanising, chromating and an additional sealing. RotoSil enables the hardware components to appear in a smooth silver tone. The quality requirements of RAL-RG 607/3 are exceeded, also the protection effect against acids has been decisively improved. The surface protection regulations of the RAL quality assurance association in Velbert, Germany, are more than fulfilled.

Surface protection with RotoSil exceed requirements of the following standards:

- RAL 607/3 (72 hours protection from white rust and 240 hours protection against red rust Inclusive of cycle testing to 60,000 cycles).
- BS 6375 pt. 2 "Performance of Windows."
- BS EN 1670:2007 part 5.6, grade 5 (480 hours building hardware corrosion resistance).



Viewed from the inside

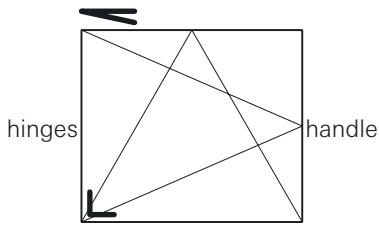

Roto NT Royal

Tilt first

Security gearing

Timber 9/13mm axis,
flat rebate

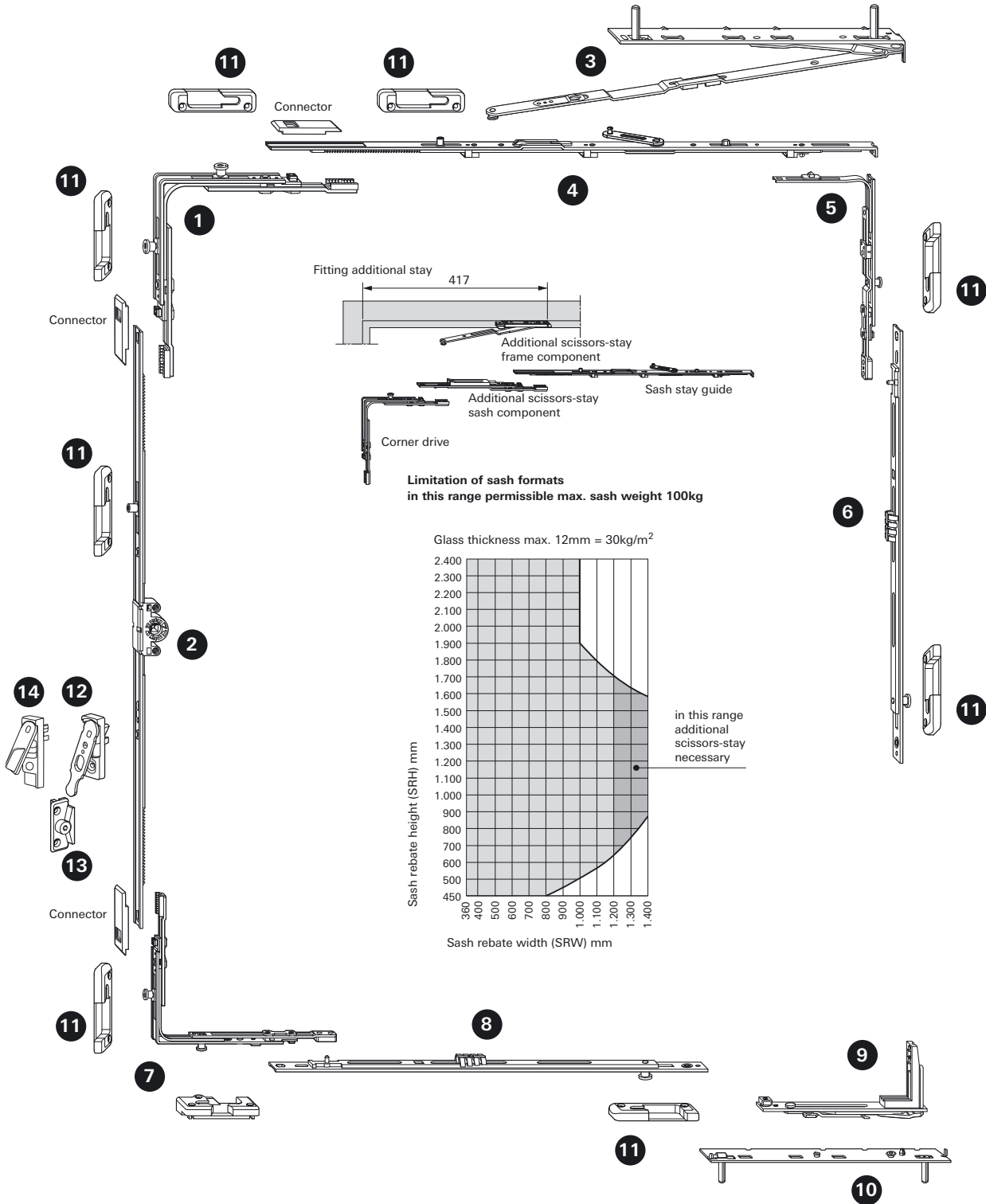

Application range

Sash rebate width, min - max	360 - 1400mm
Sash rebate height, min - max	450 - 2400mm
Sash weight, max	100kg
Connector x 3 per tilt & turn set	350 401

Roto NT Royal

Tilt first

Security parts

Corner drives			
Item number		SRH	Part Number
1	2	V 451 - 2400	260 274

2. Espagnolette			
SRH		Length (mm)	Part Number
450 - 620		400	259 718*
621 - 800	1	E 580	259 719
801 - 1200	1	E 980	259 720
1201 - 1600	2	E 1380	259 721
1601 - 2000	2	E 1780	259 762
2001 - 2400	4	E 2180	259 763

* Lifting & mishandling device is not possible

3. Royal stay arm		
SRW		Part Number
360 - 800		L 324 662 R 324 863
801 - 1400		L 324 864 R 324 865

4. Royal stay guide			
SRW		Length (mm)	Part Number
360 - 410		300	253 811
411 - 600		490	253 812
601 - 800		690	253 813
801 - 1000	1	E 890	253 814
1001 - 1200	1	E 1090	253 815

Additional stay 292 022 is required on sashes over 1200mm wide, increasing the maximum sash rebate width to 1400mm.

5. Centre lock stay guide connector	1	P	280 836
-------------------------------------	---	---	---------

Additional information:

NT connector 350 401 x 3 per tilt and turn set

NT cam adjustment tool 258 191

9mm axis, Royal jig 259 145

13mm axis, Royal jig 259 150

Locking cam **E** Compression adjustable cam

Locking cam **P** Compression adjustable, security cam

Locking cam **V** Height & compression adjustable, security cam

Timber 9/13mm axis, flat rebate

6. Security centre lock (vertical)			
SRH		Size	Part Number
490 - 700	1	P 200	255 284
701 - 900	1	P 400	255 285
901 - 1100	1	P 600	255 286
1101 - 1300	1	P 600 connectable	281 417
	1	P 200	255 284
1301 - 1500	1	P 600 connectable	281 417
	1	P 400	255 285
1501 - 1700	1	P 600 connectable	281 417
	1	P 600	255 286
1701 - 1900	2	P 600 connectable	281 417 x 2
	1	P 200	255 284
1901 - 2100	2	P 600 connectable	281 417 x 2
	1	P 400	255 285
2101 - 2300	2	P 600 connectable	281 417 x 2
	1	P 600	255 286
2301 - 2400	3	P 600 connectable	281 417 x 3
	1	P 200	255 284

Tilt first corner drives (for tilt first window only)

Item	Description	Part Number
7	Tilt first security corner drive 2	V 260 274
	Tilt first striker	L 287 590 R 287 591

8. Security centre lock (horizontal)			
SRW		Size	Part Number
600 - 800	1	P 200	255 284
801 - 1000	1	P 400	255 285
1001 - 1200	1	P 600	255 286
1201 - 1400	1	P 600 connectable	281 417
	1	P 200	255 284

9. Corner hinge		
Max. sash weight		Part Number
100 kg		L 254 026 R 254 028

10. Pivot rest		
Max. sash weight		Part Number
100 kg		L 254 035 R 254 038

11. Security striker	L 260 386 R 260 387
----------------------	------------------------

12. Sash lifting device	260 538
-------------------------	---------

13. Striker for sash lifting device	260 540
-------------------------------------	---------

14. Mis-operation device		Part Number
9mm axis		L 349 128 R 349 129
13mm axis		L 349 130 R 349 131

Roto NT Royal

Tilt first

Security gearing

Timber 9/13mm axis,
7/8 groove

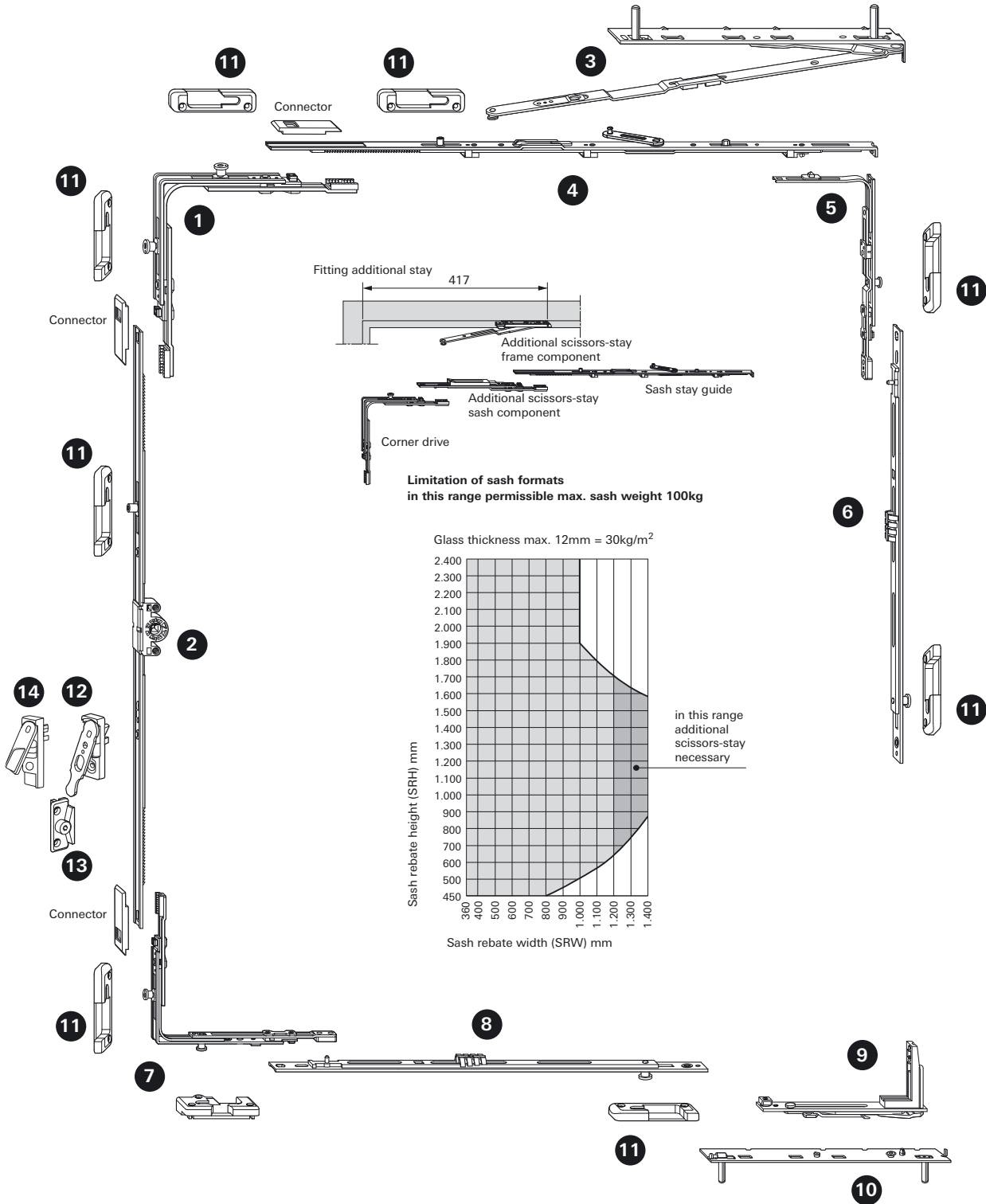

Application range

Sash rebate width, min - max	360 - 1400mm
Sash rebate height, min - max	450 - 2400mm
Sash weight, max	100kg
Connector x 3 per tilt & turn set	350 401

Roto NT Royal

Tilt first

Security parts

Corner drives			
Item number		SRH	Part Number
1	2	V 451 - 2400	260 274

2. Espagnolette			
SRH		Length (mm)	Part Number
450 - 620		400	259 718*
621 - 800	1	E 580	259 719
801 - 1200	1	E 980	259 720
1201 - 1600	2	E 1380	259 721
1601 - 2000	2	E 1780	259 762
2001 - 2400	4	E 2180	259 763

* Lifting & mishandling device is not possible

3. Royal stay arm		
SRW		Part Number
360 - 800		L 324 662 R 324 863
801 - 1400		L 324 864 R 324 865

4. Royal stay guide			
SRW		Length (mm)	Part Number
360 - 410		300	253 811
411 - 600		490	253 812
601 - 800		690	253 813
801 - 1000	1	E 890	253 814
1001 - 1200	1	E 1090	253 815

Additional stay 292 022 is required on sashes over 1200mm wide, increasing the maximum sash rebate width to 1400mm.

5. Centre lock stay guide connector	1	P	280 836
-------------------------------------	---	---	---------

Additional information:

NT connector 350 401 x 3 per tilt and turn set

NT cam adjustment tool 258 191

9mm axis, Royal jig 259 145

13mm axis, Royal jig 259 150

Locking cam **E** Compression adjustable cam

Locking cam **P** Compression adjustable, security cam

Locking cam **V** Height & compression adjustable, security cam

Timber 9/13mm axis,
7/8 groove

6. Security centre lock (vertical)			
SRH		Size	Part Number
490 - 700	1	P 200	255 284
701 - 900	1	P 400	255 285
901 - 1100	1	P 600	255 286
1101 - 1300	1	P 600 connectable	281 417
	1	P 200	255 284
1301 - 1500	1	P 600 connectable	281 417
	1	P 400	255 285
1501 - 1700	1	P 600 connectable	281 417
	1	P 600	255 286
1701 - 1900	2	P 600 connectable	281 417 x 2
	1	P 200	255 284
1901 - 2100	2	P 600 connectable	281 417 x 2
	1	P 400	255 285
2101 - 2300	2	P 600 connectable	281 417 x 2
	1	P 600	255 286
2301 - 2400	3	P 600 connectable	281 417 x 3
	1	P 200	255 284

Tilt first corner drives (for tilt first window only)

Item	Description	Part Number
7	Tilt first security corner drive	2 V 260 274
	Tilt first striker	L 287 917 R 287 918

8. Security centre lock (horizontal)			
SRW		Size	Part Number
600 - 800	1	P 200	255 284
801 - 1000	1	P 400	255 285
1001 - 1200	1	P 600	255 286
1201 - 1400	1	P 600 connectable	281 417
	1	P 200	255 284

9. Corner hinge		
Max. sash weight		Part Number
100 kg		L 254 026 R 254 028

10. Pivot rest		
Max. sash weight		Part Number
100 kg		L 254 035 R 254 038

11. Security striker	L 260 388 R 260 389
----------------------	------------------------

12. Sash lifting device	260 538
-------------------------	---------

13. Striker for sash lifting device	260 544
-------------------------------------	---------

14. Mis-operation device		Part Number
9mm axis		L 349 128 R 349 129
9mm axis		L 349 130 R 349 131

Roto NT Royal

Tilt first

Standard gearing

Timber 9/13mm axis,
flat rebate

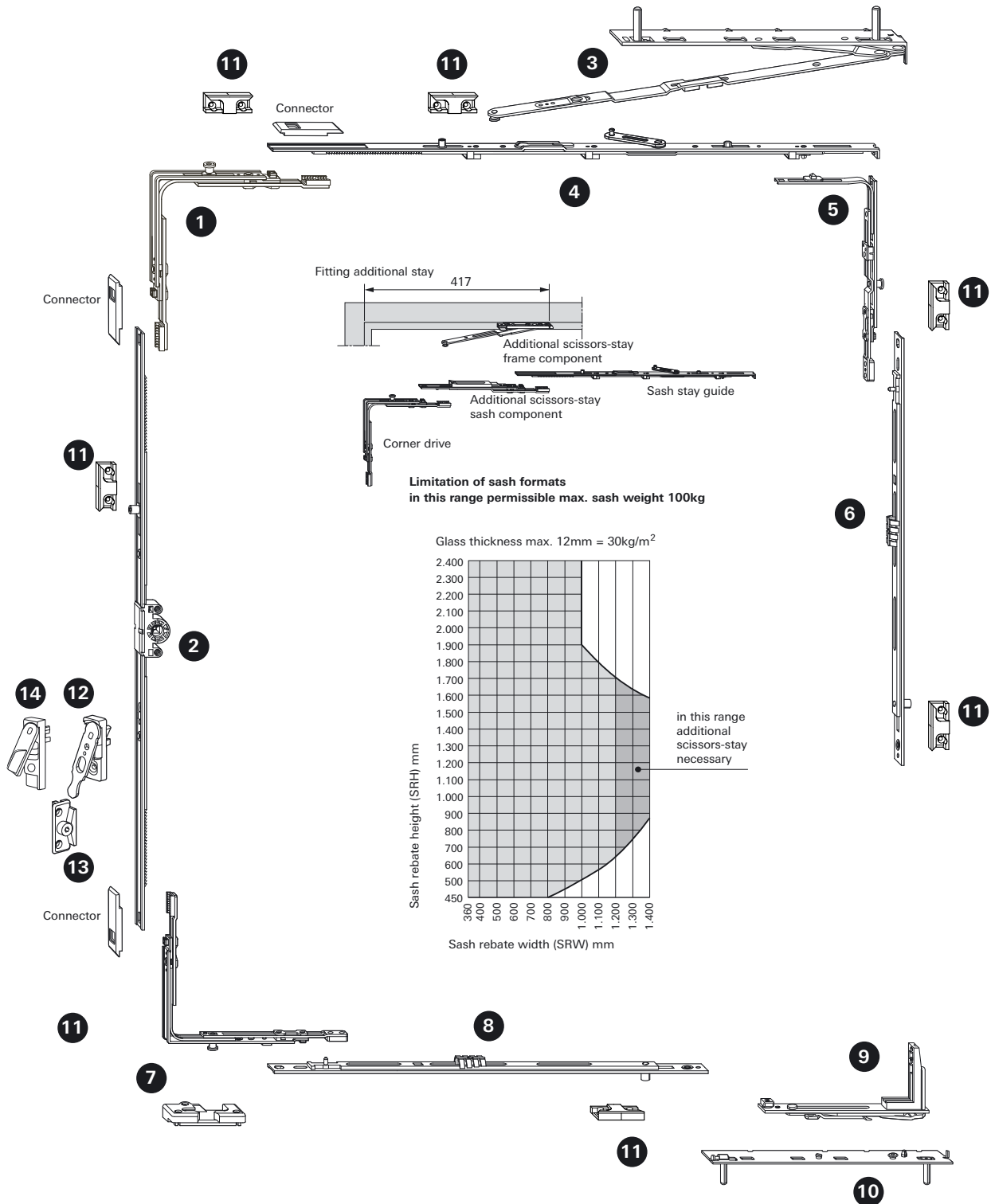

Application range

Sash rebate width, min - max 360 - 1400mm

Sash rebate height, min - max 450 - 2400mm

Sash weight, max 100kg

Connector x 3 per tilt & turn set 350 401

Roto NT Royal

Tilt first

Standard parts

Corner drives			
Item number		SRH	Part Number
1	1	P 451 - 2400	260 277

2. Espagnolette			
SRH		Length (mm)	Part Number
450 - 620		400	259 718*
621 - 800	1	E 580	259 719
801 - 1200	1	E 980	259 720
1201 - 1600	2	E 1380	259 721
1601 - 2000	2	E 1780	259 762
2001 - 2400	4	E 2180	259 763

* Lifting & mishandling device is not possible

3. Royal stay arm		
SRW		Part Number
360 - 800		L 324 662 R 324 863
801 - 1400		L 324 864 R 324 865

4. Royal stay guide			
SRW		Length (mm)	Part Number
360 - 410		300	253 811
411 - 600		490	253 812
601 - 800		690	253 813
801 - 1000	1	E 890	253 814
1001 - 1200	1	E 1090	253 815

Additional stay 292 022 is required on sashes over 1200mm wide, increasing the maximum sash rebate width to 1400mm.

5. Centre lock stay guide connector	1	P	280 836
-------------------------------------	---	----------	---------

Additional information:

NT connector 350 401 x 3 per tilt and turn set

NT cam adjustment tool 258 191

9mm axis, Royal jig 259 145

13mm axis, Royal jig 259 150

Timber 9/13mm axis,
flat rebate

6. Centre lock (vertical)			
SRH		Size	Part Number
801 - 1200	1	E 400	255 280
1201 - 1400	1	E 600	255 281
1401 - 1800	1	E 600 connectable	255 282
	1	E 400	255 280
1801 - 2000	1	E 600 connectable	255 282
	1	E 600	255 281
2001 - 2400	2	E 600 connectable	255 282 x 2
	1	E 400	255 280

Tilt first corner drives (for tilt first window only)			
Item	Description		Part Number
7	Tilt first corner drive	1	P 260 277
	Tilt first striker		L 287 590 R 287 591

8. Centre lock (horizontal)			
SRW		Size	Part Number
801 - 1200	1	E 400	255 285
1201 - 1400	1	E 600	255 286

9. Corner hinge		
Max. sash weight		Part Number
100 kg		L 254 026 R 254 028

10. Pivot rest		
Max. sash weight		Part Number
100 kg		L 254 035 R 254 038

11. Compression striker	18mm rebate	260 360
	20mm rebate	260 362

12. Sash lifting device	260 538
-------------------------	---------

13. Striker for sash lifting device	260 540
-------------------------------------	---------

14. Mis-operation device		
		Part Number
9mm axis		L 349 128 R 349 129
13mm axis		L 349 130 R 349 131

Locking cam **E**

Locking cam **P**

Compression adjustable cam

Compression adjustable, security cam

Roto NT Royal

Tilt first

Standard gearing

Timber 9/13mm axis,
7/8 groove

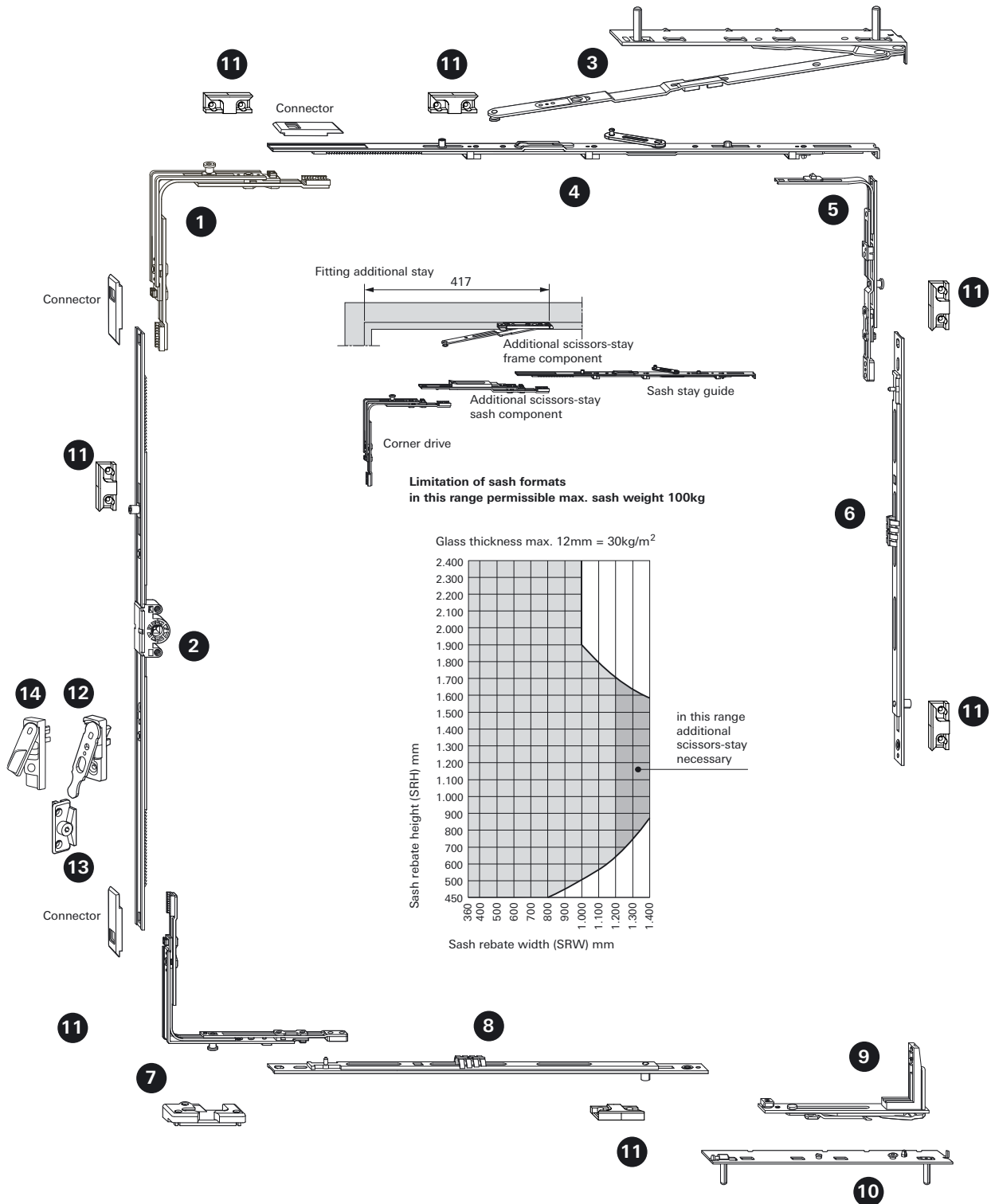

Roto NT Royal

Tilt first

Standard parts

Corner drives			
Item number		SRH	Part Number
1	1	P 451 - 2400	260 277

2. Espagnolette			
SRH		Length (mm)	Part Number
450 - 620		400	259 718*
621 - 800	1	E 580	259 719
801 - 1200	1	E 980	259 720
1201 - 1600	2	E 1380	259 721
1601 - 2000	2	E 1780	259 762
2001 - 2400	4	E 2180	259 763

* Lifting & mishandling device is not possible

3. Royal stay arm		
SRW		Part Number
360 - 800		L 324 662 R 324 863
801 - 1400		L 324 864 R 324 865

4. Royal stay guide			
SRW		Length (mm)	Part Number
360 - 410		300	253 811
411 - 600		490	253 812
601 - 800		690	253 813
801 - 1000	1	E 890	253 814
1001 - 1200	1	E 1090	253 815

Additional stay 292 022 is required on sashes over 1200mm wide, increasing the maximum sash rebate width to 1400mm.

5. Centre lock stay guide connector	1	P	280 836
-------------------------------------	---	----------	---------

Additional information:

NT connector 350 401 x 3 per tilt and turn set

NT cam adjustment tool 258 191

9mm axis, Royal jig 259 145

13mm axis, Royal jig 259 150

Timber 9/13mm axis,
7/8 groove

6. Centre lock (vertical)			
SRH		Size	Part Number
801 - 1200	1	E 400	255 280
1201 - 1400	1	E 600	255 281
1401 - 1800	1	E 600 connectable	255 282
	1	E 400	255 280
1801 - 2000	1	E 600 connectable	255 282
	1	E 600	255 281
2001 - 2400	2	E 600 connectable	255 282 x 2
	1	E 400	255 280

Tilt first corner drives (for tilt first window only)			
Item	Description		Part Number
7	Tilt first corner drive	1	P 260 277
	Tilt first striker		L 287 917 R 287 918

8. Centre lock (horizontal)			
SRW		Size	Part Number
801 - 1200	1	E 400	255 285
1201 - 1400	1	E 600	255 286

9. Corner hinge		
Max. sash weight		Part Number
100 kg		L 254 026 R 254 028

10. Pivot rest		
Max. sash weight		Part Number
100 kg		L 254 035 R 254 038

11. Compression striker	260 364
-------------------------	---------

12. Sash lifting device	260 538
-------------------------	---------

13. Striker for sash lifting device	260 540
-------------------------------------	---------

14. Mis-operation device		
		Part Number
9mm axis		L 349 128 R 349 129
13mm axis		L 349 130 R 349 131

Locking cam **E**

Locking cam **P**

Compression adjustable cam

Compression adjustable, security cam

Sash preparation

Routing details

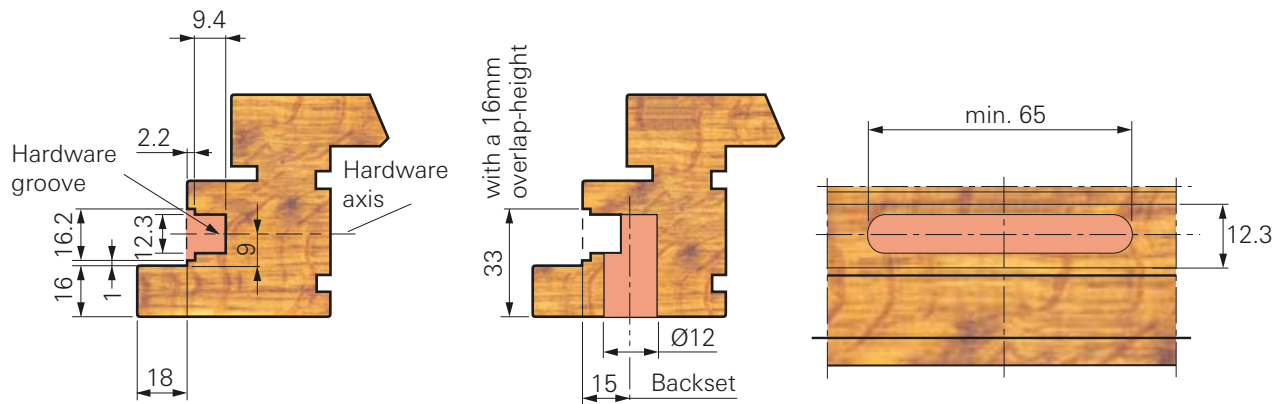

Handle drilling and routing

Gear case sprocket and lugs' drill holes for the window handle.

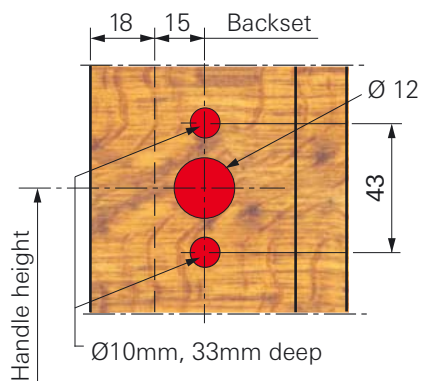

Fix the window handle with Ø5mm countersunk screws DIN965 (M5 X ...) in the espagnolette gear casing.

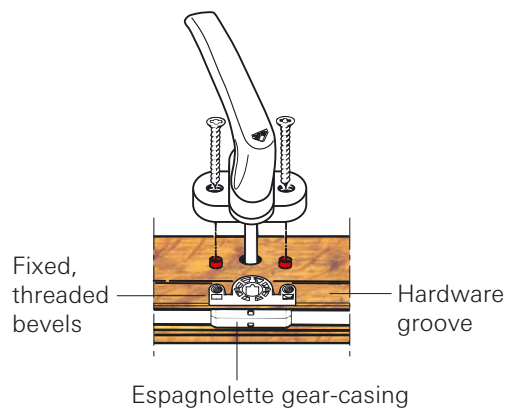

RotoLine window handle with lugs and 7mm spindle

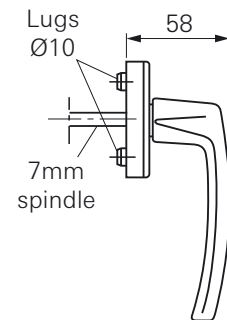



Cropping extensions

When cropping manually, the extension(s) should be cut so as to allow a gap of 33mm between the ends of the faceplates as shown.

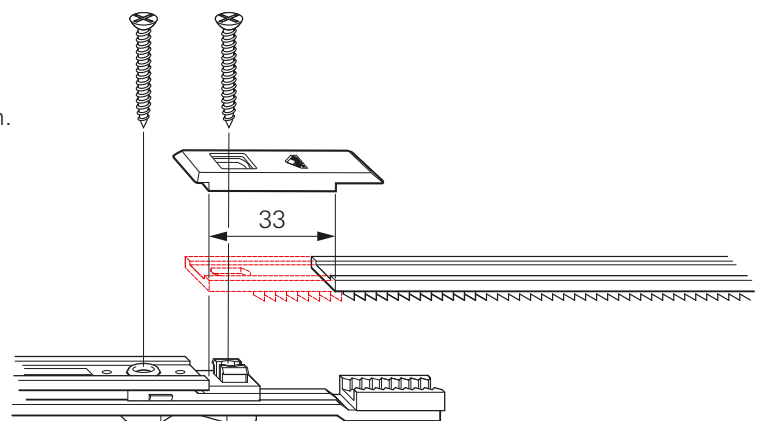



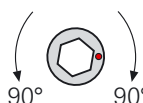
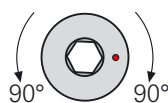

This gap is then bridged using a dedicated connector piece. Part number 350401

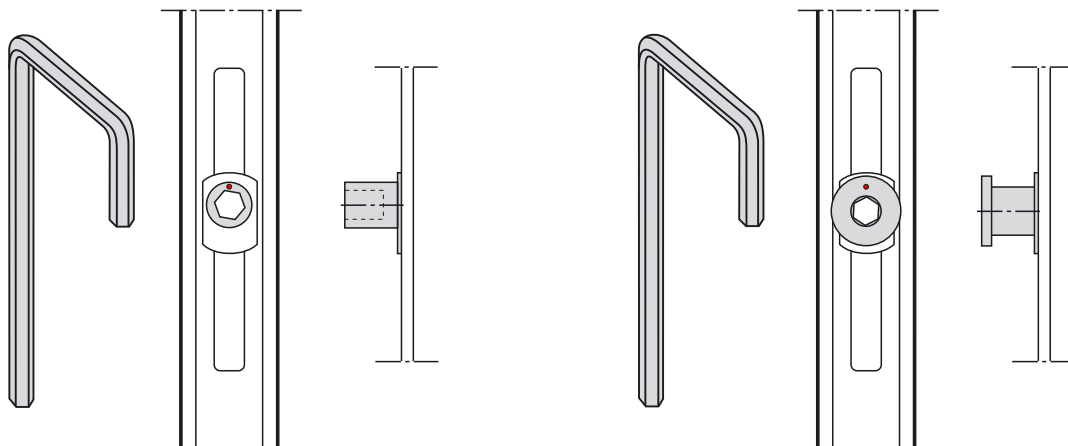

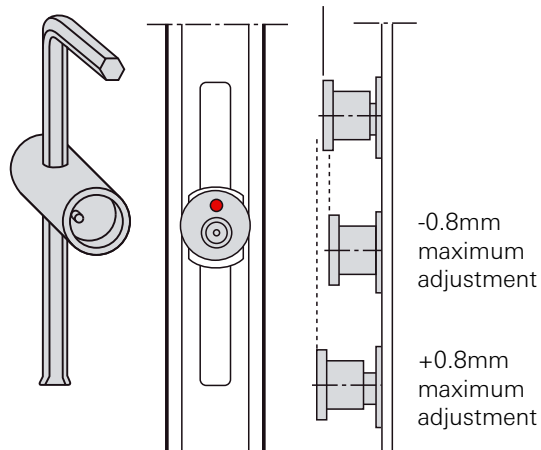
Locking cam options and adjustment

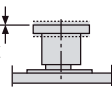
Locking cam E	Locking cam range in °	Gasket compression adjustment in mm	Locking cam P	Locking cam range in °	Gasket compression adjustment in mm
	Original position 			Original position 	
	 90° 90°	+/- 0.8		 90° 90°	+/- 0.8

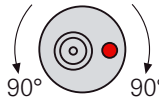
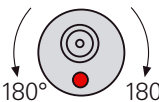

Locking cam V 0 = original position 	Adjustment range in °	Gasket compression adjustment in mm 	Height adjustment in mm 	
	Original position 			
	 90° 90°	+/- 0.8	+/- 0.2	
	 180° 180°		+/- 0.4	
	 270° 270°	+/- 0.8	+/- 0.6	
	 360° 360°		+/- 0.8	

Roto NT Royal

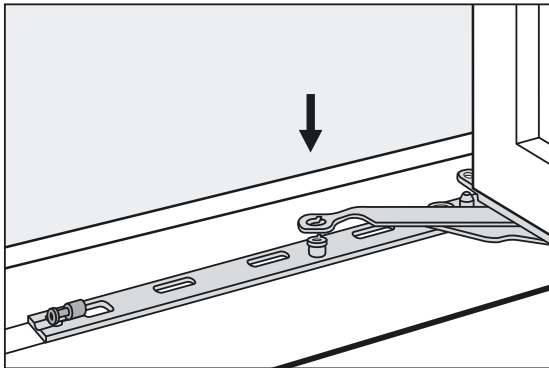

Pivot rest R

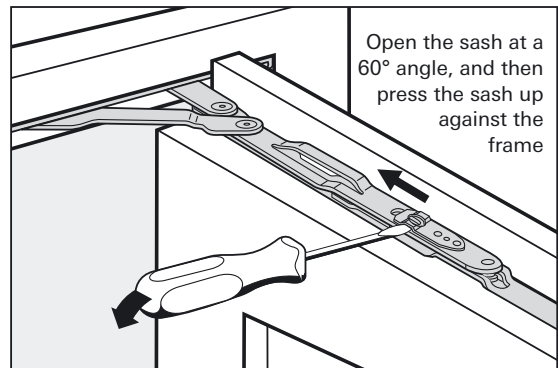

Stay arm R

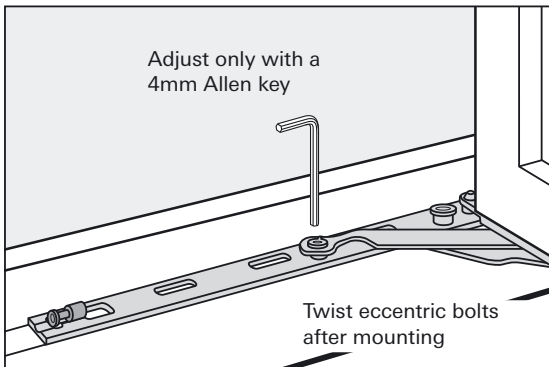

Pivot rest R

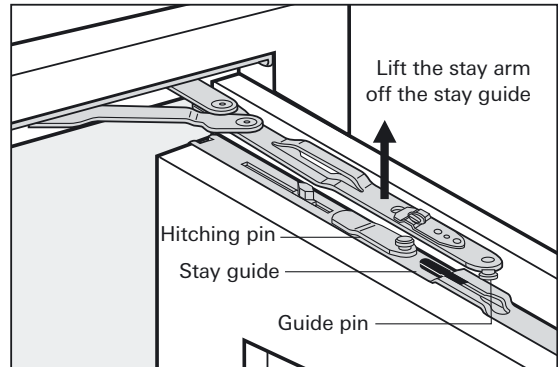

Stay arm R

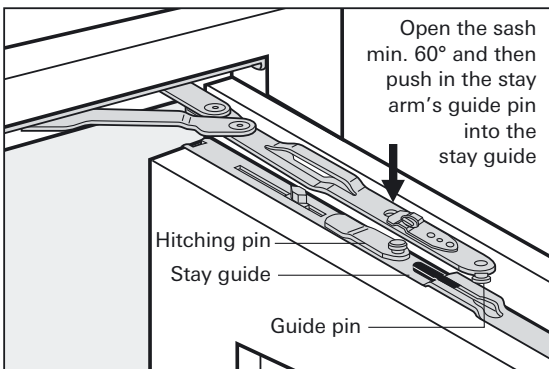

Stay arm R

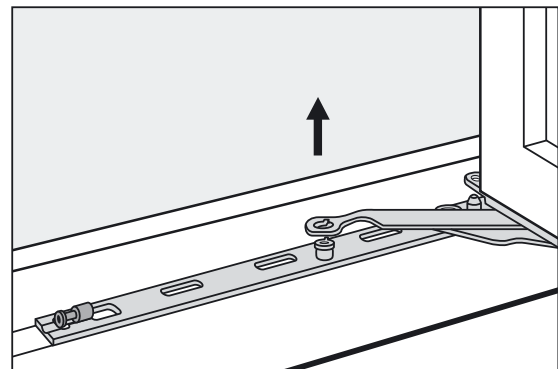

Pivot rest R

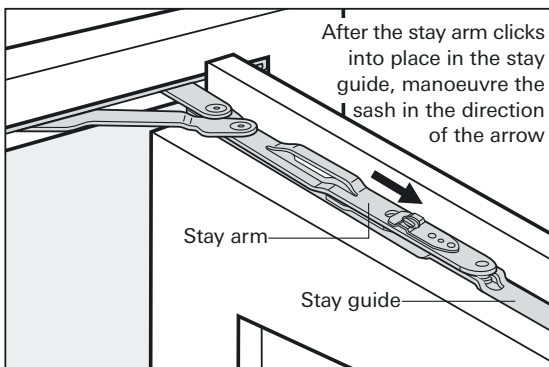

Stay arm R

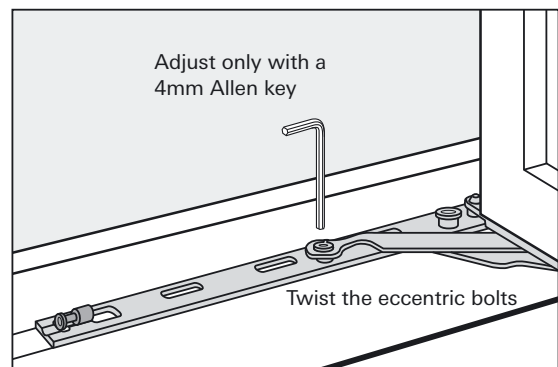

Pivot rest R

Roto NT Royal

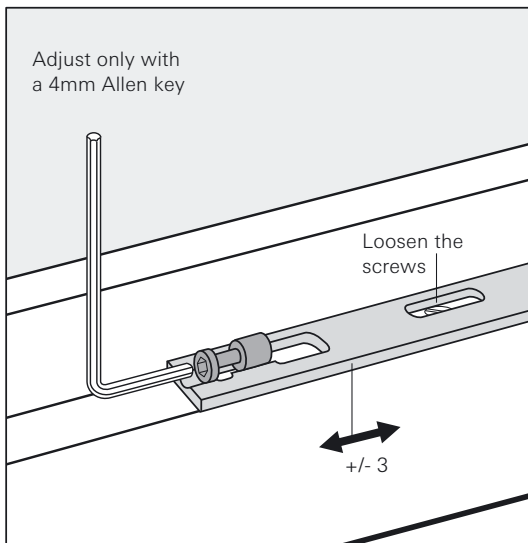

Pivot rest R

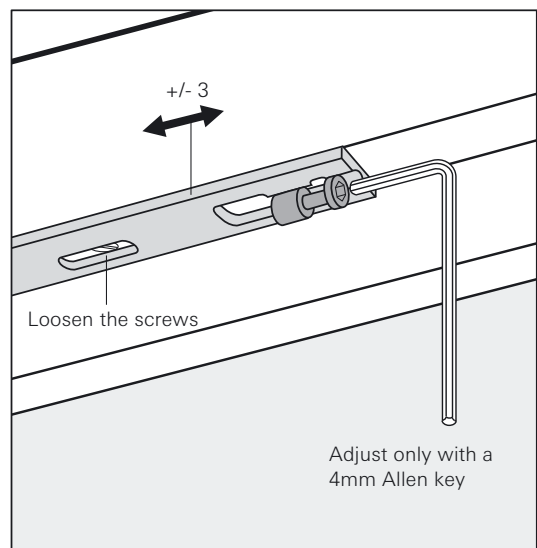

Stay arm R

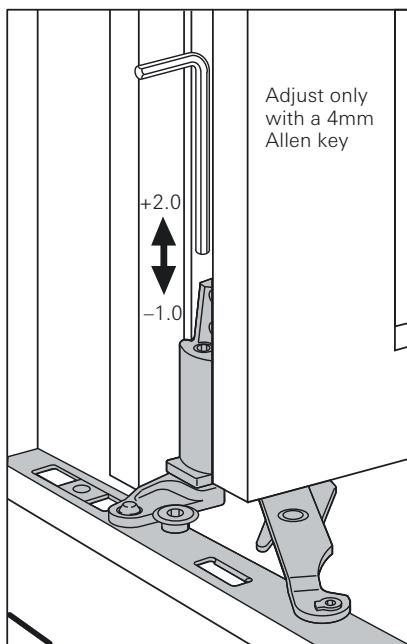

Corner hinge R

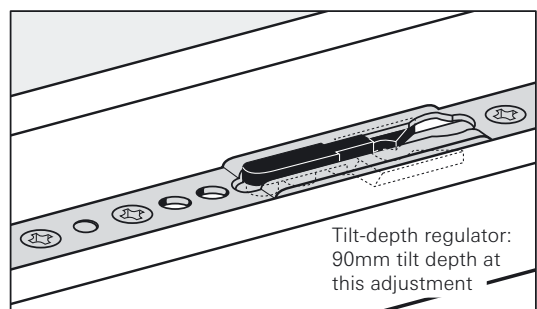

Integrated tilt-depth regulators on stay guide R, size 250.

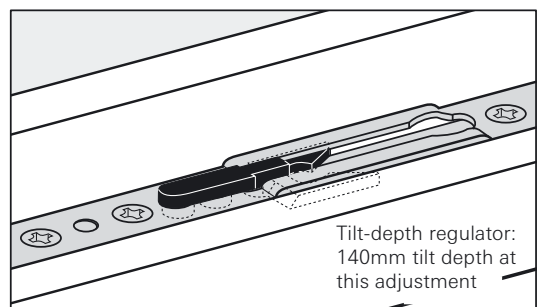

Anti-slam device integrated in the stay guide R

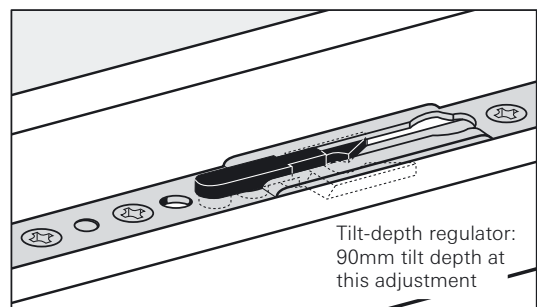

Integrated tilt-depth regulators on stay guide R, size 450.

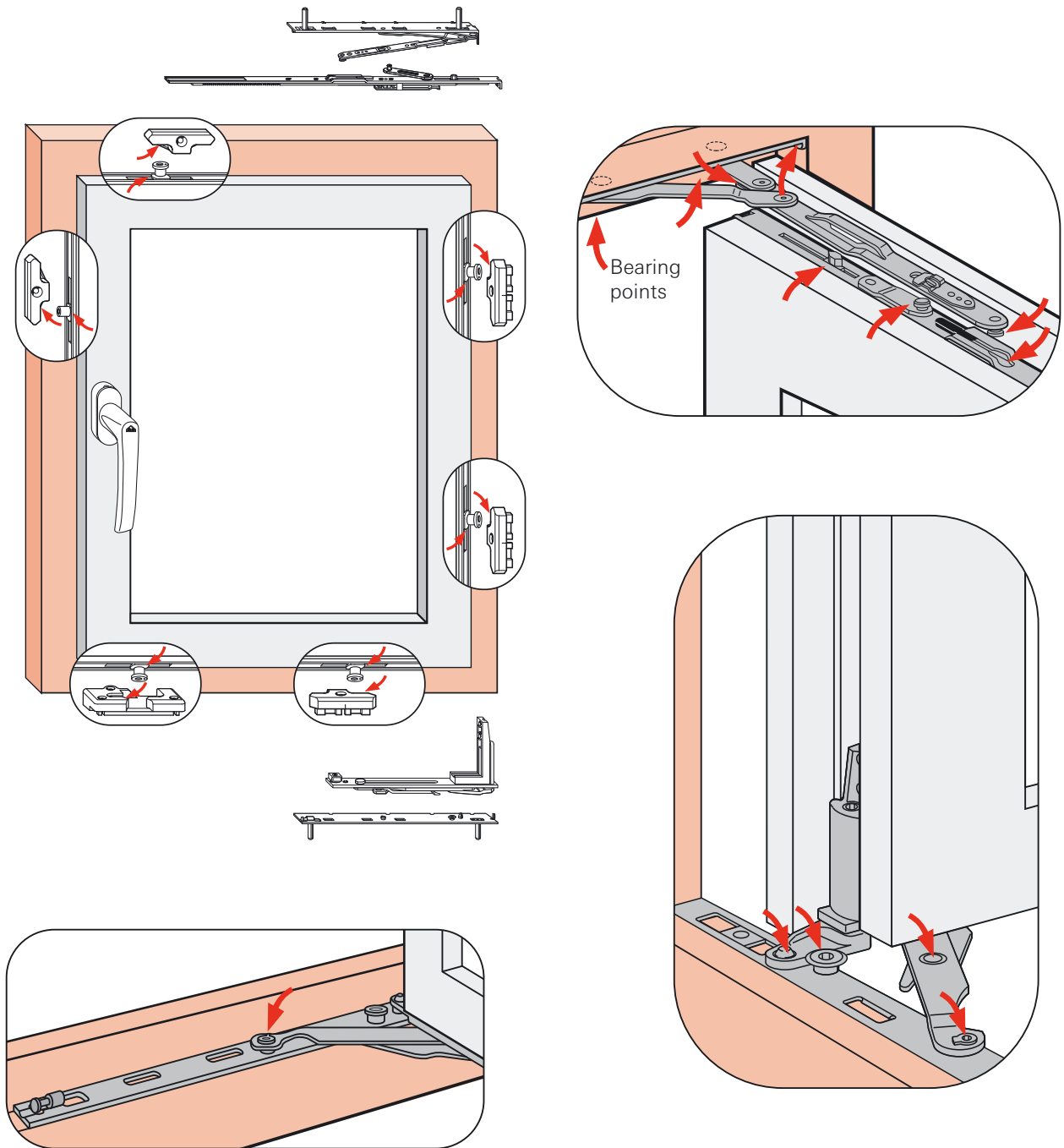

Maintenance



By means of regular greasing and oiling* (at least once a year) all operation-relevant components in the sash and frame, you maintain the smooth operation of your Roto hardware and you protect against premature wear and tear. Security strikers made of steel require

continuous greasing in order to avoid unnecessary abrasion. In addition, the individual screws are to be checked. Possible loose screws or broken off screw-heads are to be tightened or replaced immediately by a specialised company.

* Please use acid-free and non-resinous grease and/or oil from a specialised dealer

Operation

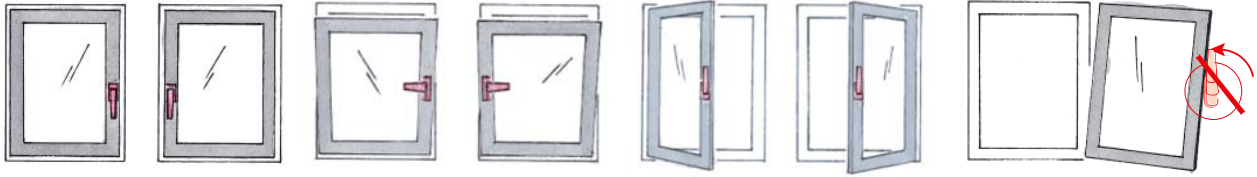

Avoid mishandling

The window must be closed before switching to the open (turn) mode to avoid mishandling.

In order to preserve **functionality** of your window and to guarantee **security**, it is imperative the directives listed below are observed.

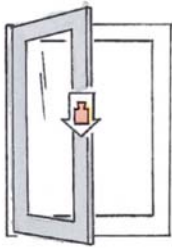

The window sash may not be burdened with additional weight

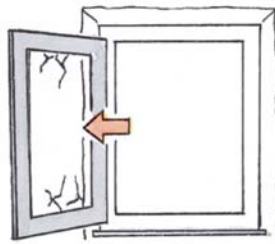

Do not allow the sash to hit or press up against the reveal



Do not place any objects between the sash and frame



Where small children or mentally handicapped persons have access to the window, the sash is to be safeguarded against turning, for example with a child-safety lock (inhibits turn mode, permits tilt-mode) or key-lockable handle.



Do not leave sashes open in the turn mode during strong winds.

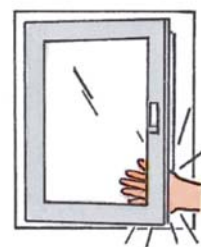

Caution! A slamming sash can lead to injuries. While closing, do not grasp between the sash and frame.



Roto Roof Windows and Hardware Ltd.

Swift Point
Rugby CV21 1QH
United Kingdom
Telephone +44 (0)1788 55 86 00
Facsimile +44 (0)1788 55 86 05
info.west@roto-frank.com
www.roto-frank.co.uk

**Roto Frank S.A.
Roto Frank Nederland**

Rue du Bosquet 1
Zoning Industriel II
1400 Nivelles
Belgique
Téléphone +32 (0)67 89 41 40
Téléfax +32 (0)67 84 14 56
info.west@roto-frank.com
www.roto-frank.com

**Roto Frank AG
Fenster- und Türtechnologie**

Stuttgarter Straße 145 – 149
D-70771 Leinfelden-Echterdingen
Telefon +49 711 7598-0
Telefax +49 711 7598-253
info@roto-frank.com
www.roto-frank.com



Interested in additional products?

Do not hesitate to ask for further information

Telephone number:
+44 (0)17 88 55 86 00