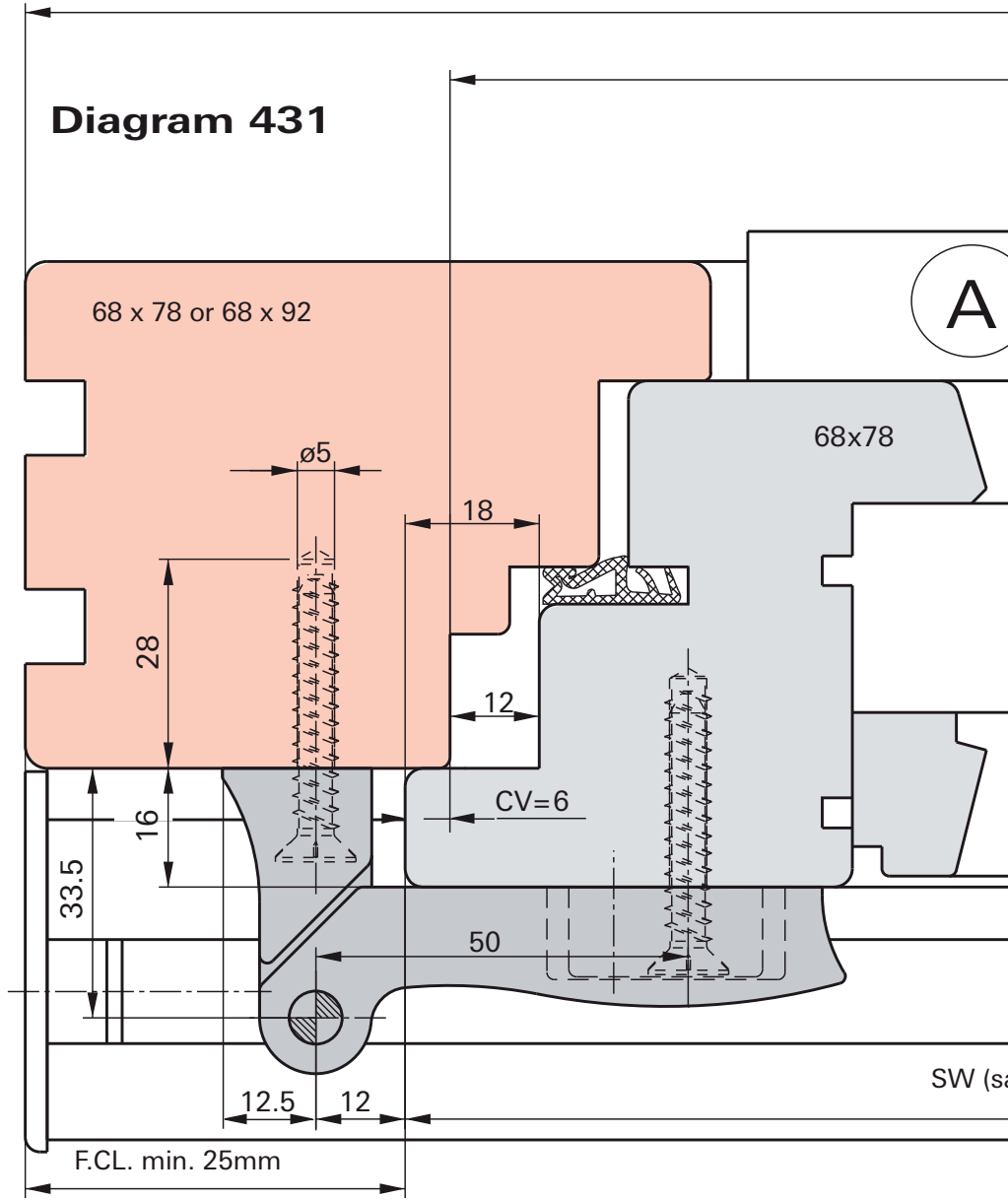
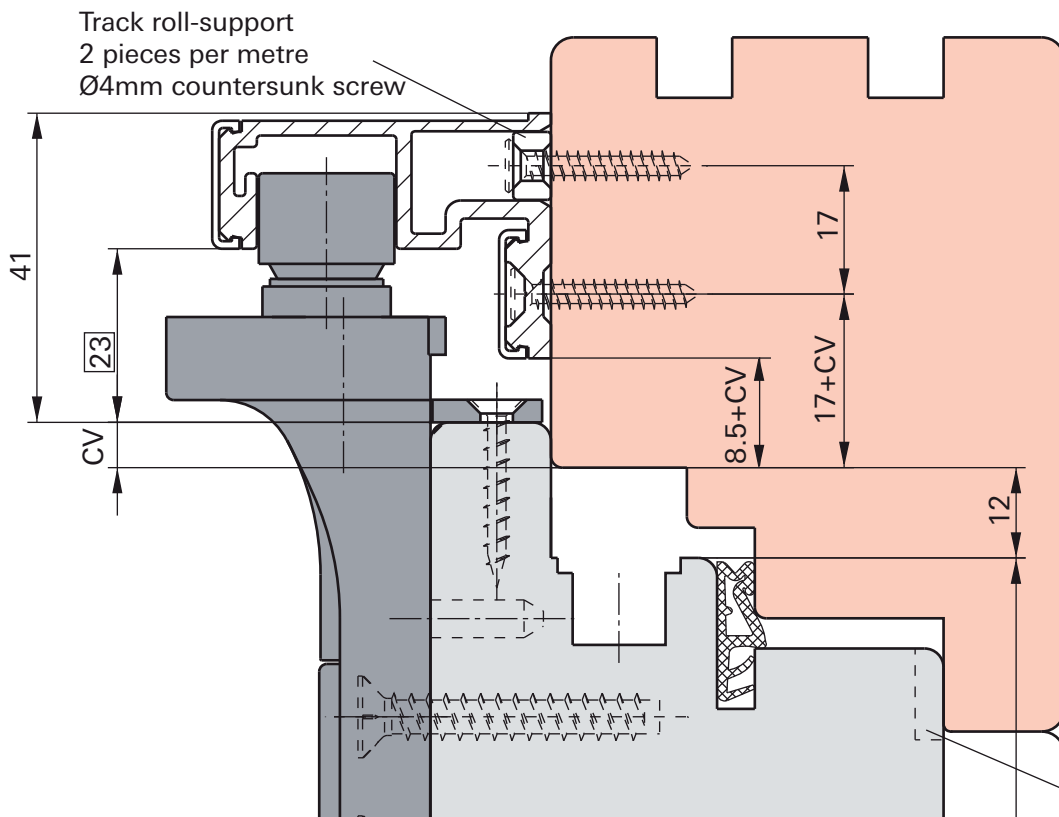

Diagram 431



Bottom running version

Top



On top running version
track must be fixed e

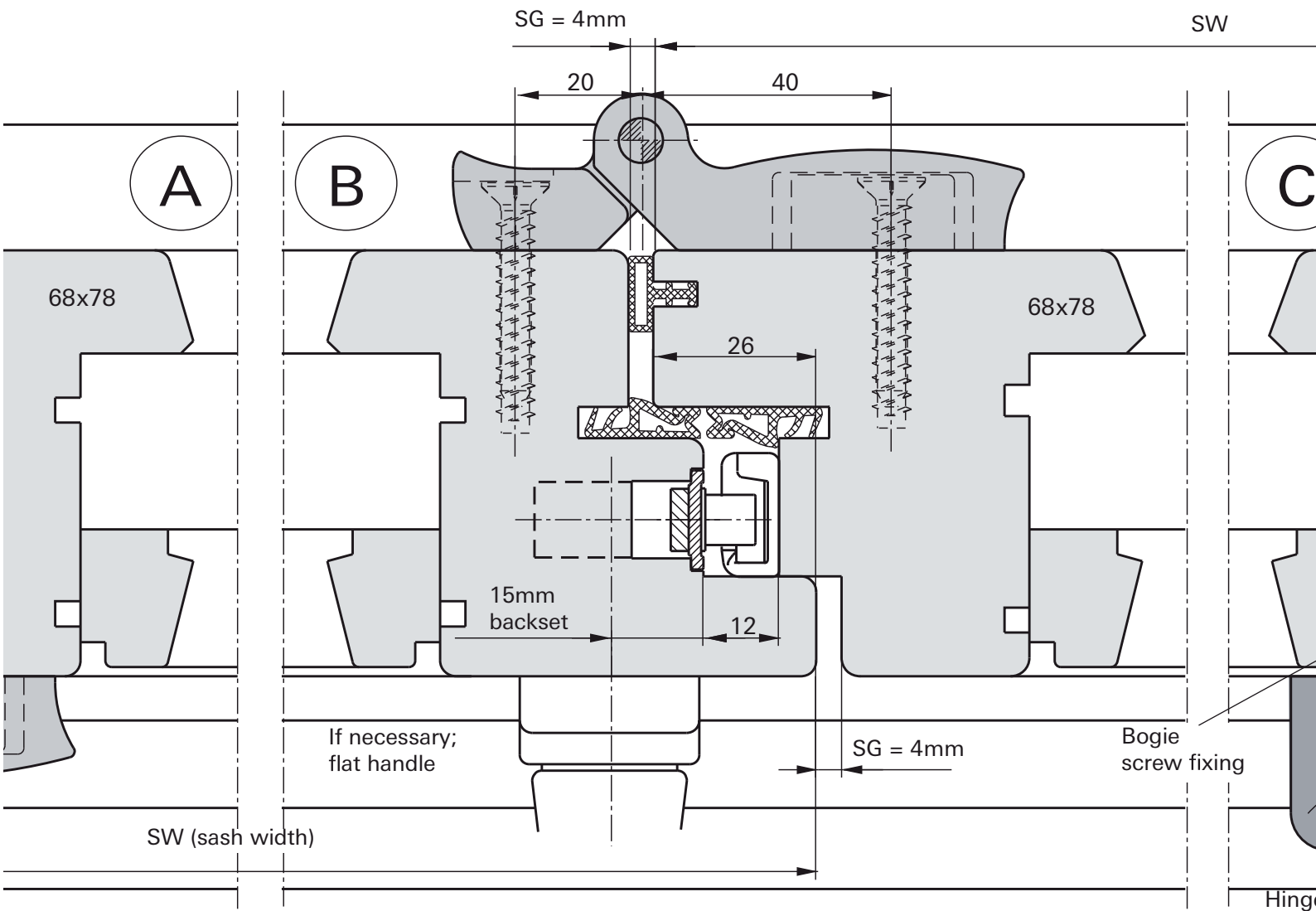

Top running version

On top running versions the roller track PVC roll-support must be fixed every 500mm.

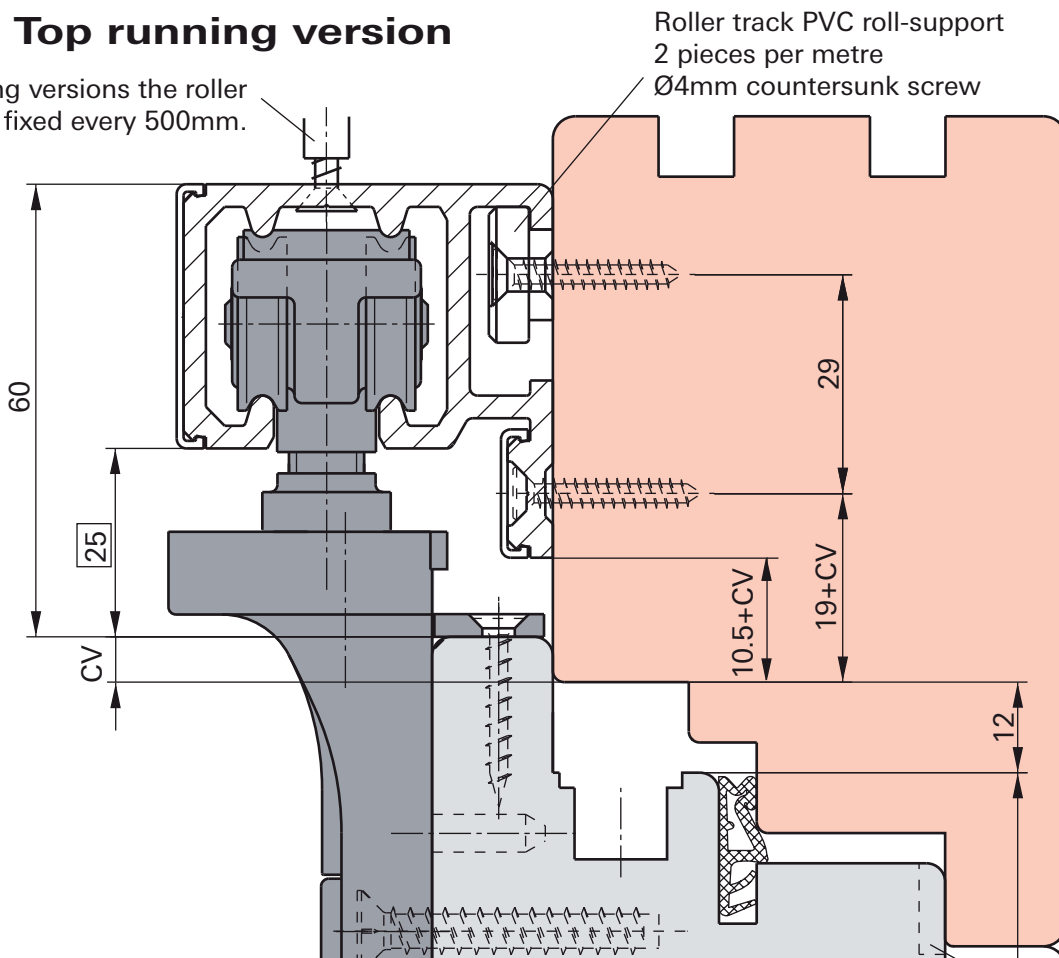

FEW

F.R.W. (frame rebate width)

SW

* In the vicinity of the support-brackets it is necessary to round off to the rebate height at the top and bottom.

C

D

SG = 4mm

Gasket; e.g. L8001 or SD16 from the Dipro Papenburg company

4.5
7

26

SG = 4mm

Bogie screw fixing

Lever-operated escape
or alternatively: with
and flush encased g

Hinge screw fixing

SW

20 12 40

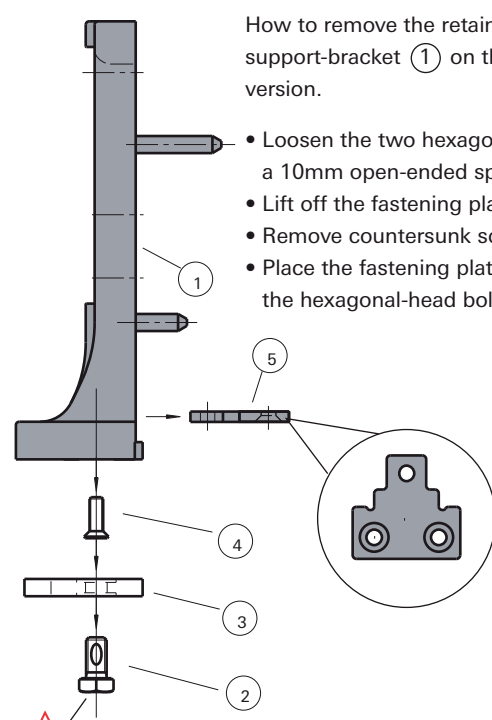
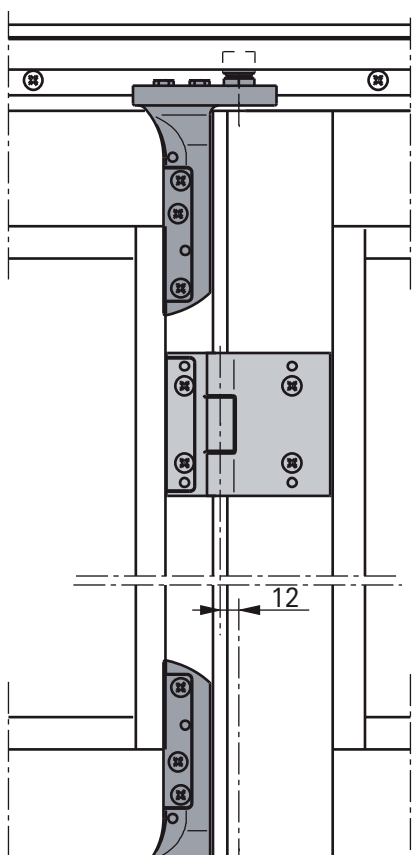

How to remove the retainer brace from the support-bracket ① on the enhanced threshold version.

- Loosen the two hexagonal-head bolts ② with a 10mm open-ended spanner.
- Lift off the fastening plate ③.
- Remove countersunk screw ④ and retainer brace ⑤.
- Place the fastening plate ③ on top again and tighten the hexagonal-head bolts ②.



Firmly tighten the screws ② with a 10mm open-ended spanner!

ts it
ate

D

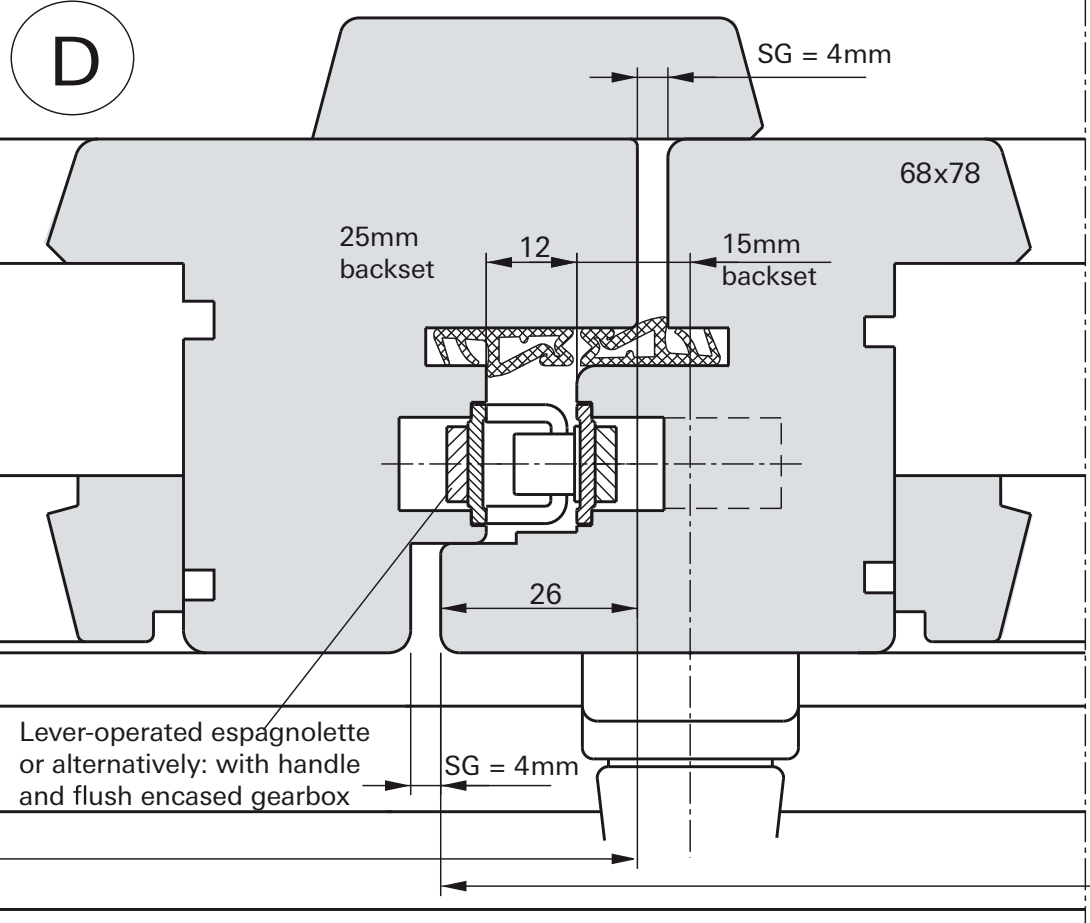

Lever-operated espagnolette
or alternatively: with handle
and flush encased gearbox

As

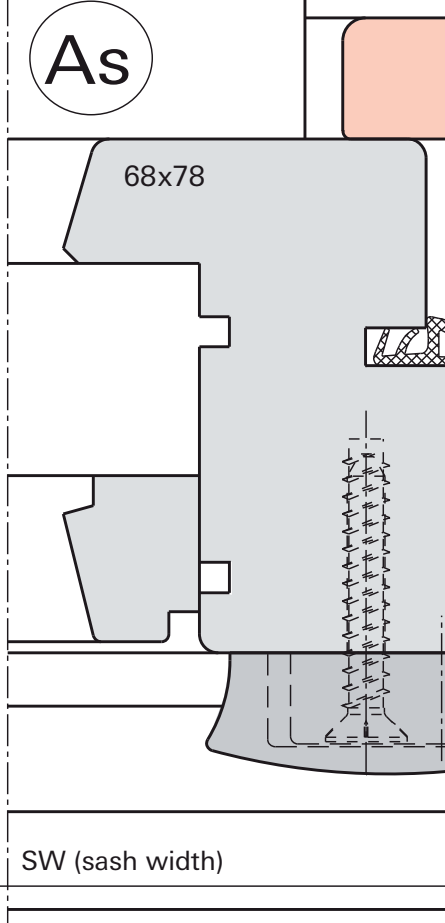

SW (sash width)

E

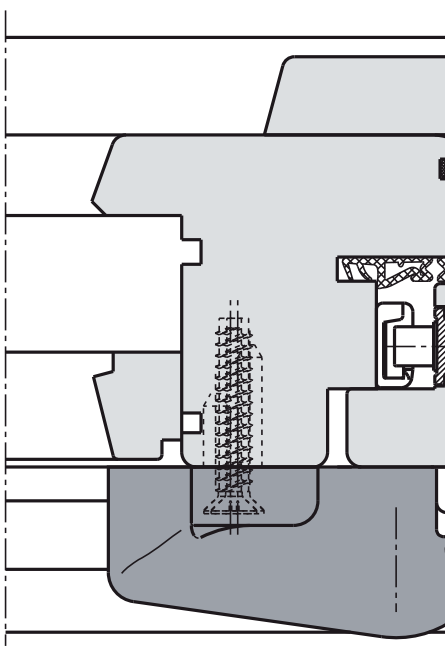

from the
ed threshold
bolts ② with
nd retainer brace ⑤.
top again and tighten

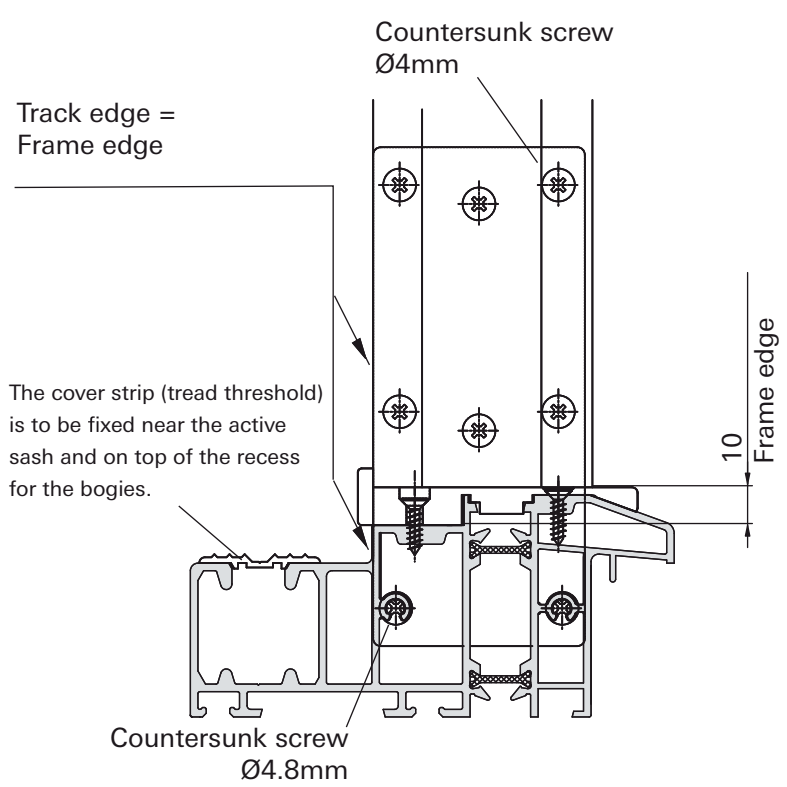

The cover strip (tread threshold)
is to be fixed near the active
sash and on top of the recess
for the bogies.

d spanner!

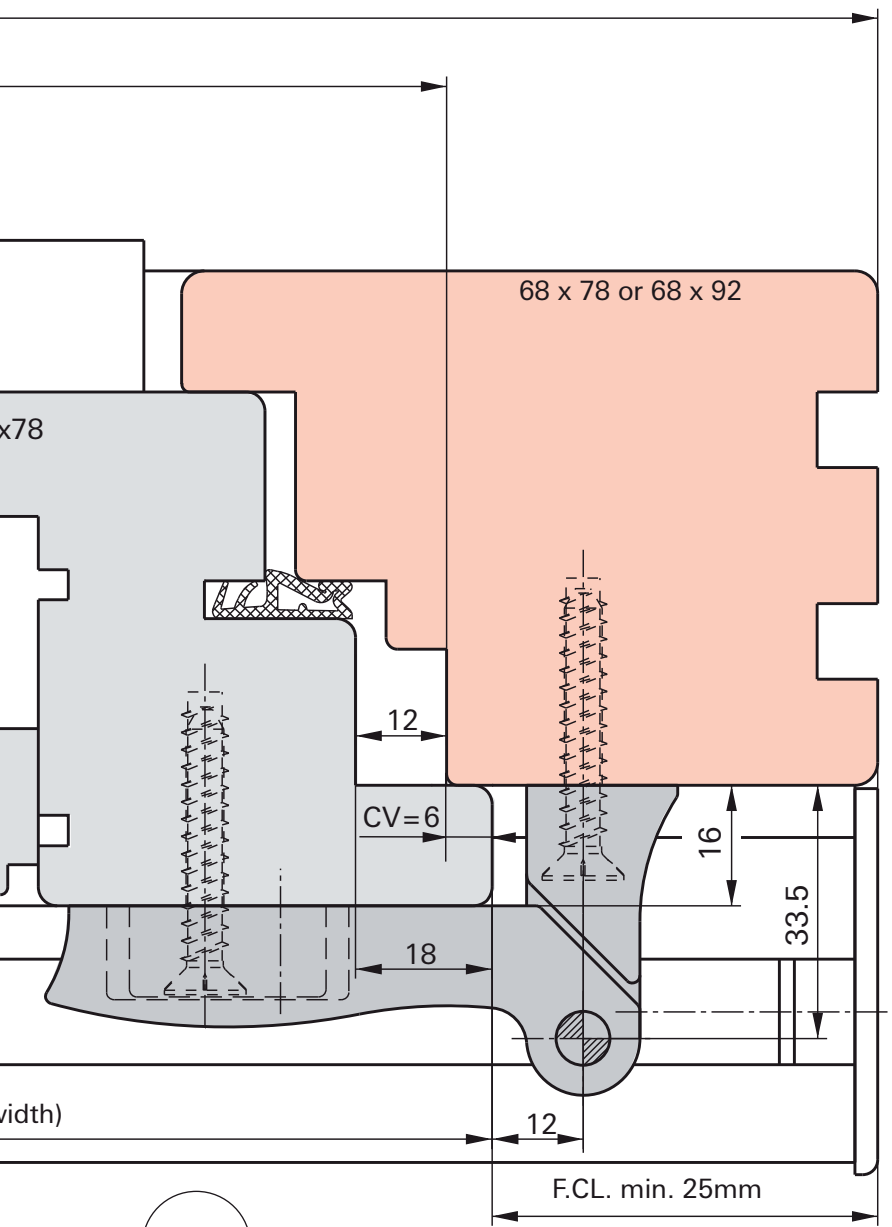

E

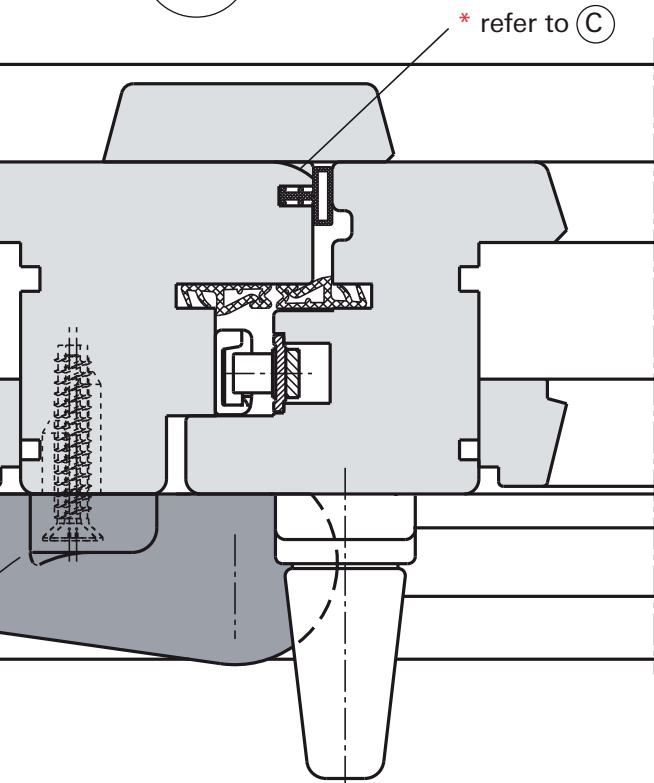

F

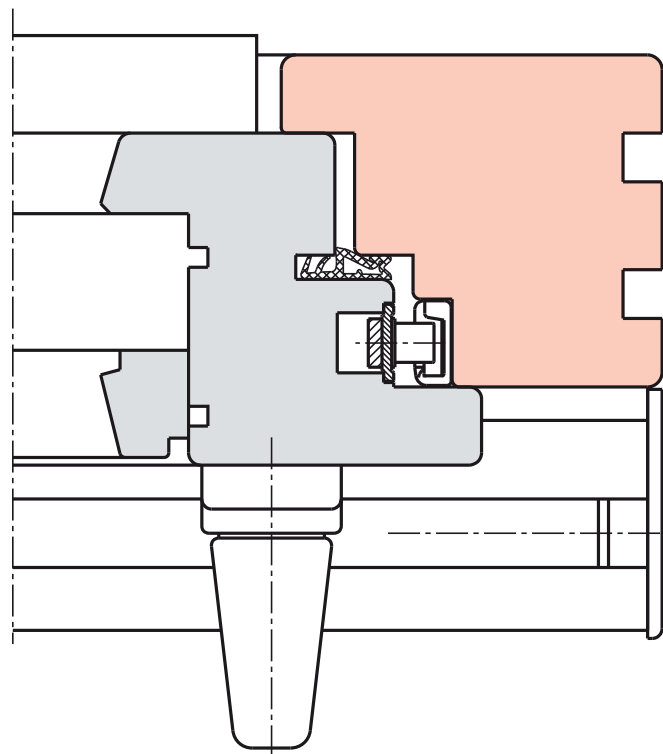

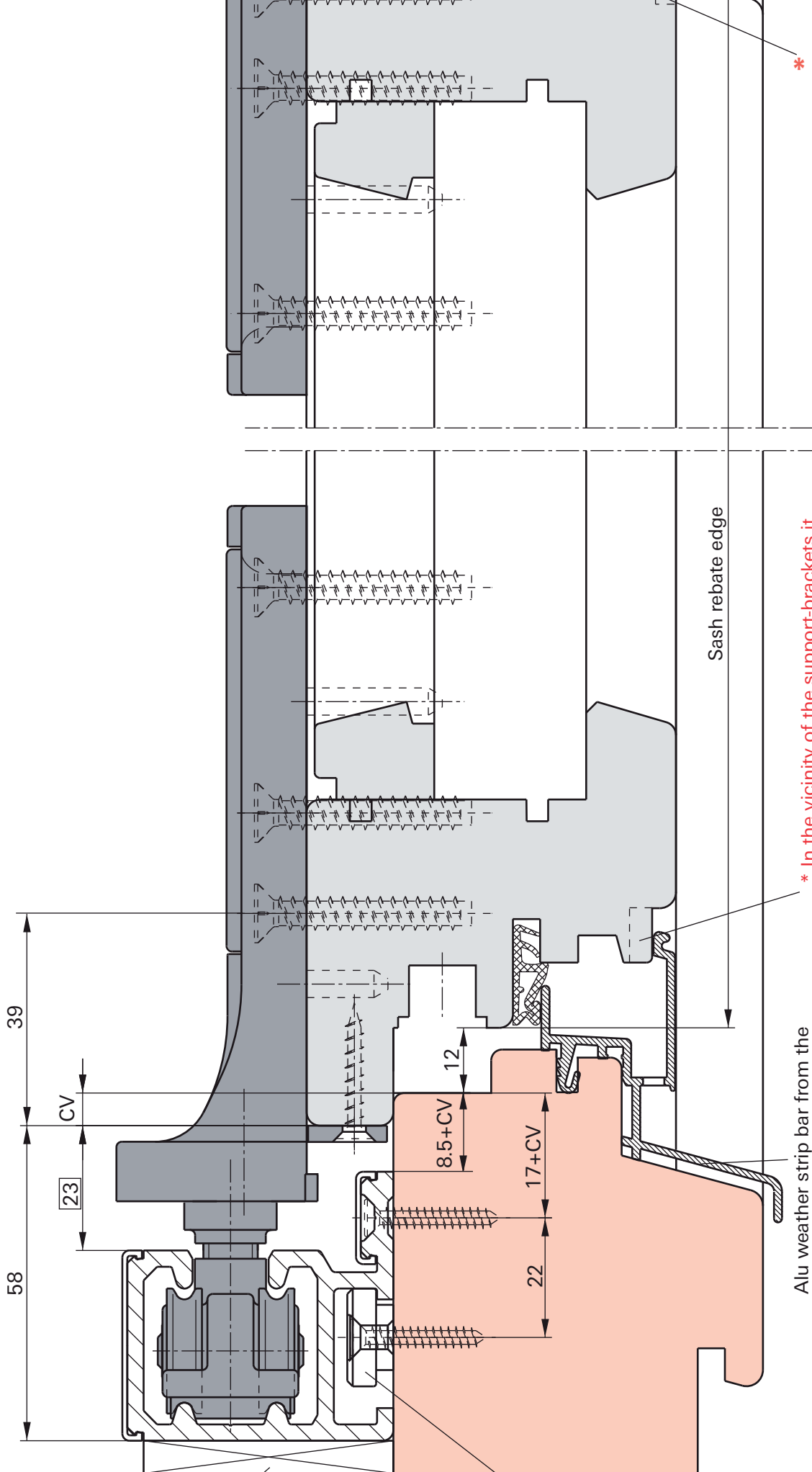

* In the vicinity of the support-brackets it is necessary to round off to the rebate height at the top and bottom.

Alu weather strip bar from the Gutmann company
Kocher LÖ 30 / Rems LÖ or similar

On the bottom-running version pack up the roller track over the entire length.

Roller track PVC roll-support
2 pieces per metre
Ø4mm countersunk screw

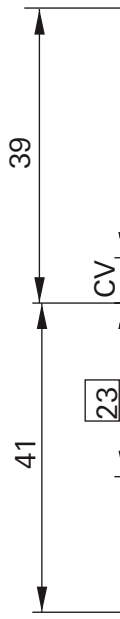

necessary to round off to the rebate height at the top and bottom.

Kocher LÖ 30 / Rems LÖ or similar

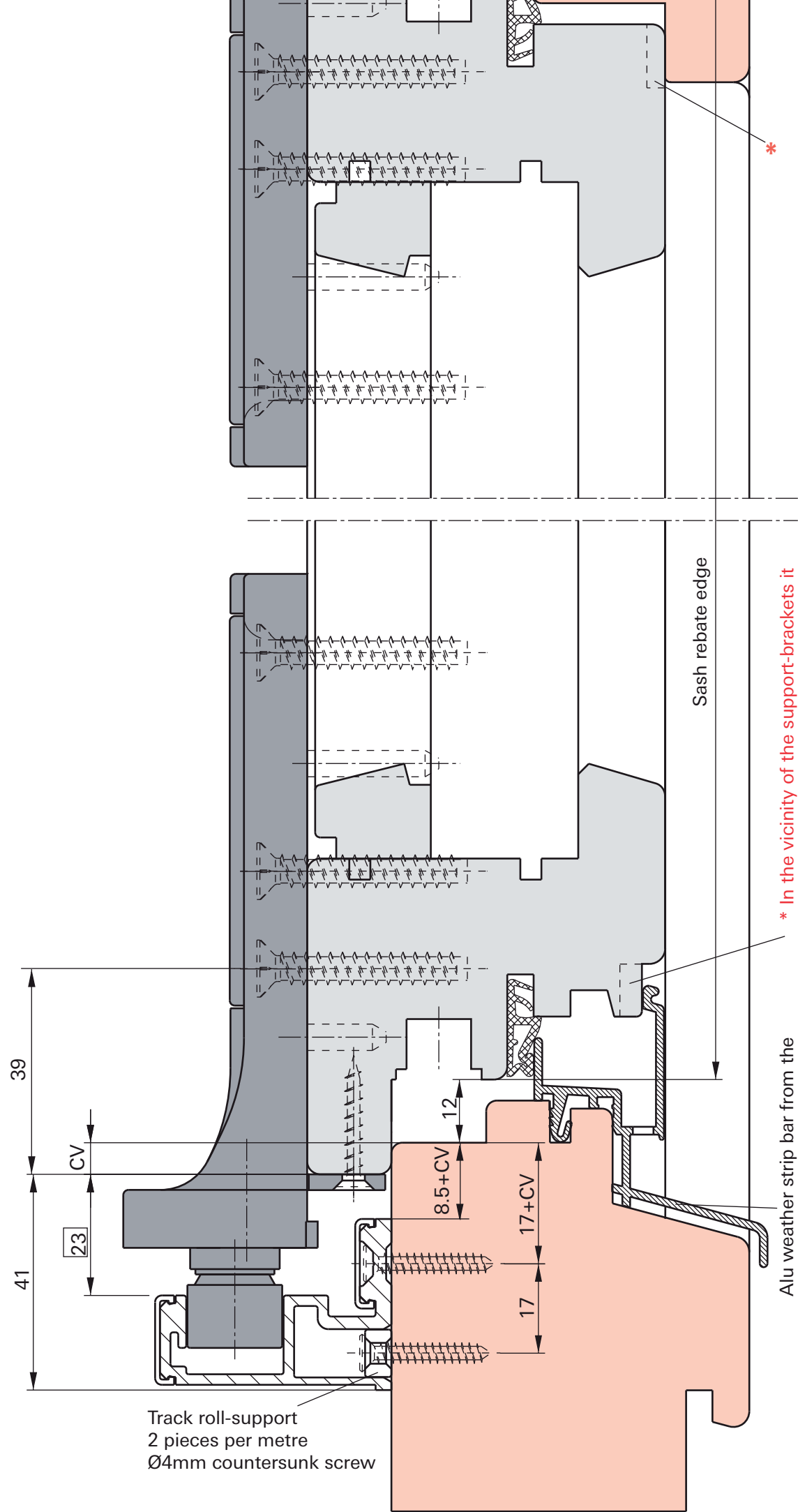

Track roll-support
2 pieces per metre
Ø4mm countersunk screw

Sash rebate edge

* In the vicinity of the support-brackets it is necessary to round off to the rebate height at the top and bottom.

Alu weather strip bar from the Gutmann company
Kocher LÖ 30 / Rems LÖ or similar

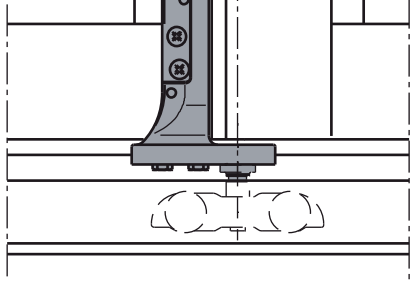

②

Firmly tighten the screws ② with a 10mm open-ended spanner!

Enhanced threshold version (Installation suggestion)

is necessary to round off to the rebate height at the top and bottom.

Gutmann company
Kocher LÖ 30 / Rems LÖ
or similar

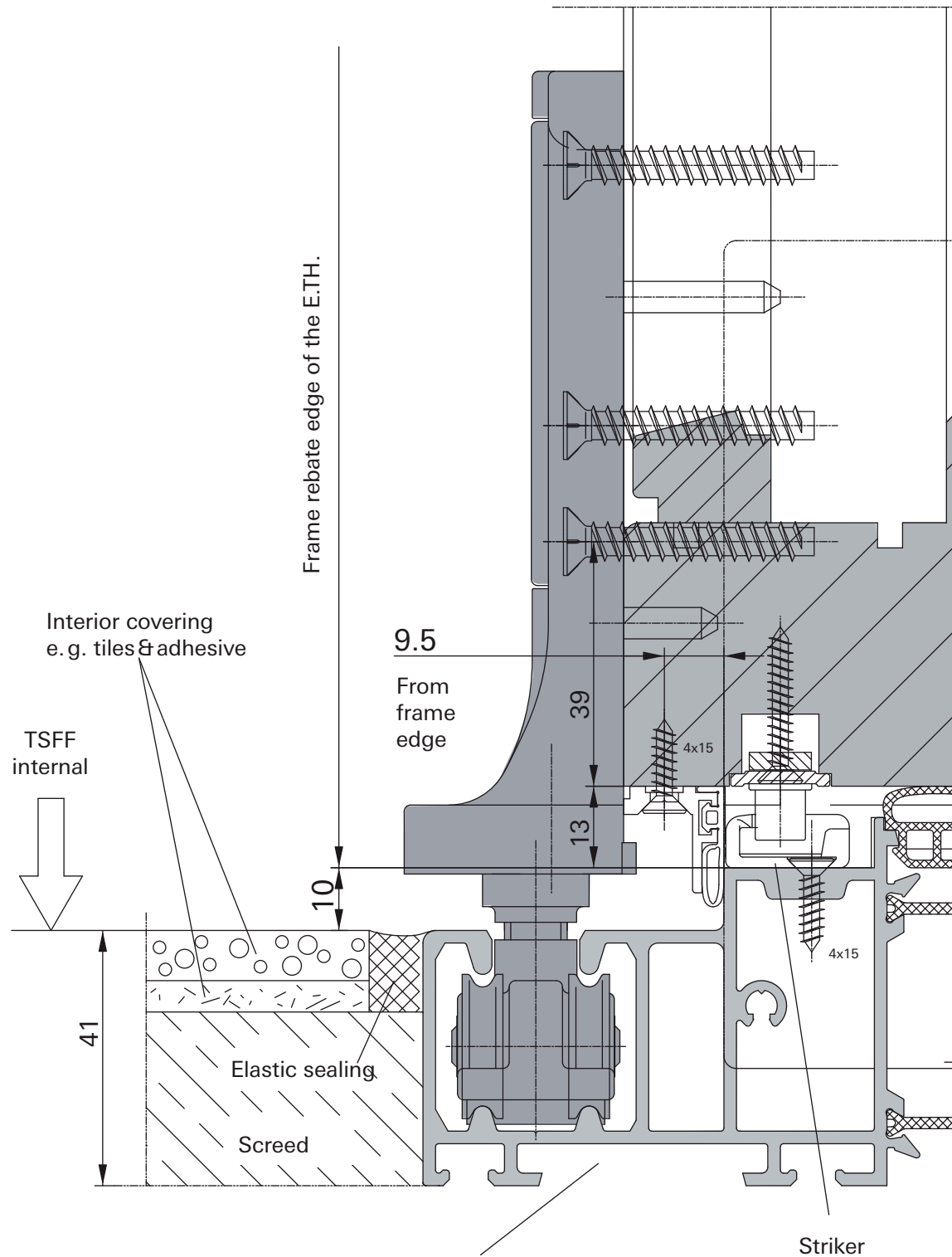

- Extension with additional profile from Veka or Schueco possible.
- Installation of anchor bolts possible.

For enhanced threshold version with Roto NT Tilt & Turn sash refer to installation instructions AB 528 GB page 31.

Countersunk screw
Ø4.8mm

spanner!

Threshold version (E.TH.) (Installation suggestion)

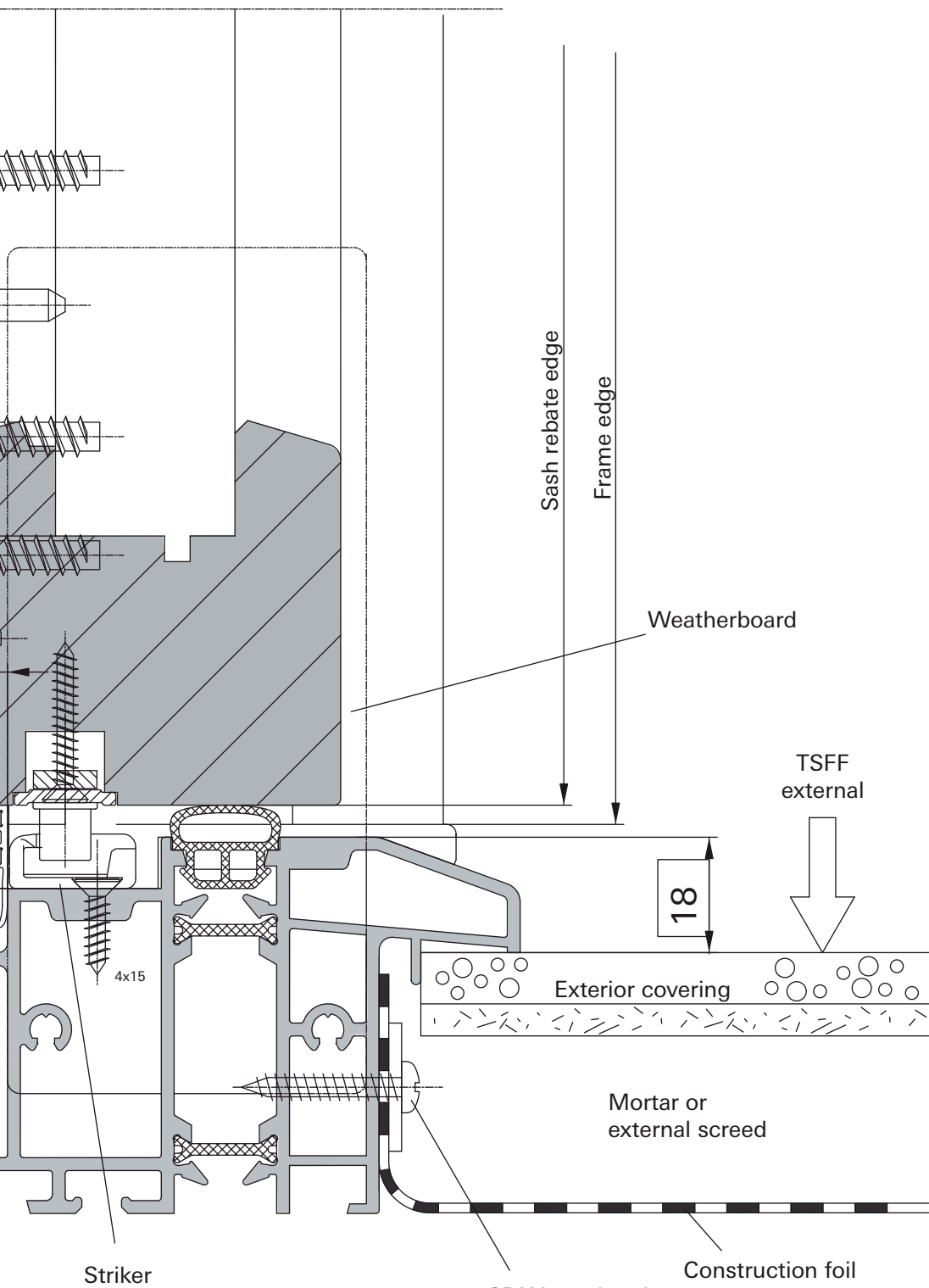

threshold version with
Turn sash refer to installation
B 528 GB page 31.

SPAX cup head screw
4x25mm galvanized (to be ordered separately)

Pa
Pro
ins

Apr

Sas

Sas
Sas
Ove

Abt

CV
F.C
SW
SH
SR
SR
E.T
TSF
FEV
FEH
FRV
SG
O.V
O.H

Sch

Right
the
the
diag
In th
the
fold
As,
C &

DIAGR



DIAGR



Patio 6080

Profile drawing supplement for the installation instructions

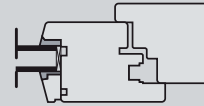

Application range

Sash rebate width: 450 to 900mm
Active sash up to 1200mm
Sash rebate height: 800 to 2400mm
Sash weight: max. 80kg
Overlap height: 16 to 25mm

General

Due to better load distribution the “bottom-running” version is favoured.

Upon installing a folding system, special attention must be paid to the fixing of the frame to the masonry brickwork in order to prevent possible bending. Pack up the entire length of the bottom roller track immediately after installation.

Abbreviations

CV	Coverage
F.CL.	Frame clearance
SW	Sash width
SH	Sash height
SRW	Sash rebate width
SRH	Sash rebate height
E.TH.	Enhanced threshold
TSFF	Top-surface of finished-floor
FEW	Frame external width
FEH	Frame external height
FRW	Frame rebate width
SG	Shadow gap
O.W.	Overlap width
O.H.	Overlap height

Sash width calculation (Timber)

- Classify according to diagram
- Determine frame outside dimension (F.E.D.)
- Select frame, sash, floating mullion and additional profiles
- Determine shadow gap (SG)
- Determine frame-clearance (F.CL.)

Diagram calculation

Diagram 321: $SW_{321} = [F.E.D. - (2 \times F.CL.) - (2 \times SG) + 60] / 3$

Diagram 330: $SW_{330} = [F.E.D. - (2 \times F.CL.) - (2 \times SG) + 60] / 3$

Diagram 431: $SW_{431} = [F.E.D. - (2 \times F.CL.) - (3 \times SG) + 90] / 4$

Diagram 541: $SW_{541} = [F.E.D. - (2 \times F.CL.) - (4 \times SG) + 120] / 5$

Diagram 550: $SW_{550} = [F.E.D. - (2 \times F.CL.) - (4 \times SG) + 120] / 5$

Diagram 532: $SW_{532} = [F.E.D. - (2 \times F.CL.) - (4 \times SG) + 120] / 5$

Diagram 651: $SW_{651} = [F.E.D. - (2 \times F.CL.) - (5 \times SG) + 150] / 6$

Diagram 633: $SW_{633} = [F.E.D. - (2 \times F.CL.) - (5 \times SG) + 150] / 6$

Diagram 761: $SW_{761} = [F.E.D. - (2 \times F.CL.) - (6 \times SG) + 180] / 7$

Diagram 770: $SW_{770} = [F.E.D. - (2 \times F.CL.) - (6 \times SG) + 180] / 7$

Diagram 743: $SW_{743} = [F.E.D. - (2 \times F.CL.) - (6 \times SG) + 180] / 7$

Diagram 871: $SW_{871} = [F.E.D. - (2 \times F.CL.) - (7 \times SG) + 210] / 8$

An Excel file to calculate the diagrams is also available upon request.

Schematic overview

Right handed versions are depicted in the schematic overview (viewed from the inside). A mirror image of each diagram can also be implemented. In the case of “0 active sashes”: the access is enabled via the first folding-sash.

As, Bs, Cs & Es = mirror images of A, B, C & E.

DIAGRAM 330

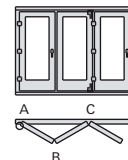

DIAGRAM 321

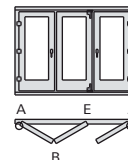

DIAGRAM 431

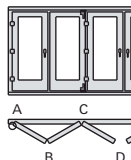

DIAGRAM 541

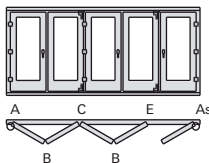

DIAGRAM 550

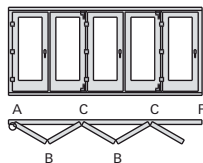

DIAGRAM 532

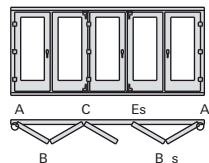

DIAGRAM 651

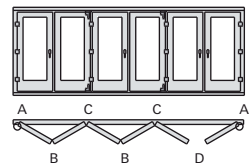

DIAGRAM 633

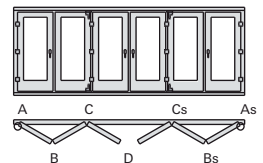

DIAGRAM 761

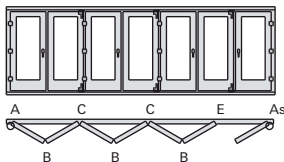

DIAGRAM 770

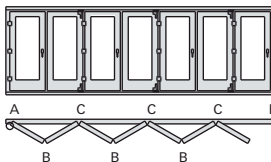

DIAGRAM 743

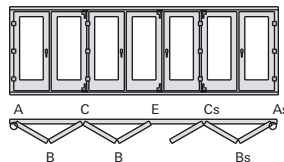

DIAGRAM 871

