

RA2000 shootbolt espagnolette

Parts catalogue

RA2000

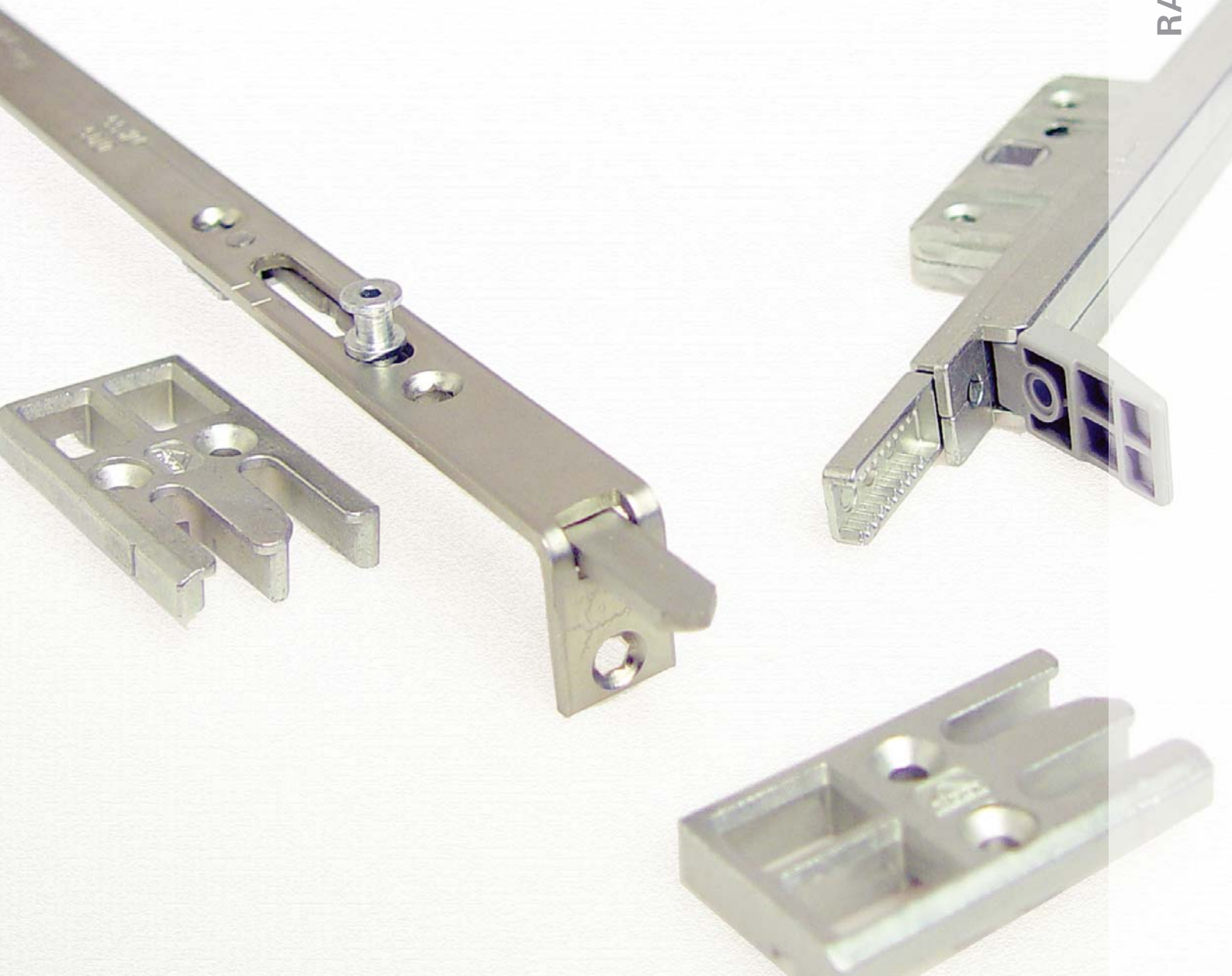

Liability exclusion

All specifications in this catalogue were compiled carefully and reviewed. Because of technical progress and legislation modifications, the data may have changed in the meantime. We therefore hope you shall understand that we cannot be held liable for the correctness, completeness, and topicality of the contents. All rights, in particular the right to copy and circulate, reserved.

Imprint

Copyright: August 2010
Roto Roof Windows and Hardware Ltd
Swift Point
Rugby
CV21 1QH
Telephone: +44 (0)1788 55 86 00
Telefax: +44 (0)1788 55 86 05
info.west@roto-frank.com
www.roto.co.uk

Product liability	4
General design description	5
RA2000 order details	6
RA2000 technical details	7
Gearbox - technical & routing details	8
Notes	9

1. Product information and appropriate use

According to this definition, fastening systems are fittings for windows made of wood or PVC-U or, and corresponding combinations of materials, the principal function of which is to lock windows.

Locking is understood to mean holding a window closed in such a way that it cannot be opened by being pulled or pushed, but can be opened in a straightforward manner, such as by the operation of a handle.

All locking elements engage into corresponding recesses in the window frame, or in locking plates, etc.

All locking elements are moved by the operation of the handle for locking and unlocking.

The fastening systems are not designed to tolerate variations in form and variations in the seal, arising from temperature differences or modifications to the construction.

The overall fitting (fastening system) in each case must be assembled from original ROTO components only. Using components which are not part of the system may result in damage which excludes liability.

In order to ensure appropriate use, correct combination with permissible fittings and means of locking (such as keys, cylinders) and accessories (such as locking plates) during assembly, fitting must be made in accordance with installation instructions or with accepted DIN standards, including those for maintenance.

Special fittings are required for windows in humid rooms and for use in environments with aggressive, corrosive air content.

Binding legal provisions must be observed.

2. Misuse

The following cases in particular constitute misuse of fastening systems - i.e. inappropriate use of the product:

- if normal use is prevented by the introduction of other and/or unsuitable objects into the fastening system or into the locking plate.
- if obstructions are introduced into the opening area and thus prevent normal use.
- if the fastening system or locking plate are interfered or tampered with, with a resultant change to the construction, to the mode of operation or to the function.
- if the exposed locking elements are assembled or worked at a later stage, e.g. repainted, in a manner which has an adverse effect on their operation.
- if inappropriate loads, exceeding the normal force of a hand, are brought to bear upon the handle linkage.
- if non-associated locking means, such as locking equipment with different dimensions or which is inserted incorrectly, are used.
- if tools or aids which have a leverage effect are used to operate the fastening system.
- if additional loads are imposed upon the window.

3. Product performance

Where product performance is not set down in concrete terms in our catalogues and promotional literature, the requirements to be imposed upon the individual fastening systems must be agreed with us.

The suitability of fastening systems for use is dependent upon, amongst other things, the frequency of operation, the mode of operation, environmental influences and maintenance.

Assembly of window fittings.

The manufacturer's specifications pertaining to the assembly of window fittings (such as the arrangement of handles or additional elements of the fitting) are binding.

4. Product maintenance

Security-relevant elements of fittings should be tested for stability and checked for wear on a regular basis. If required, the fixing screws should be tightened or components should be replaced.

Furthermore, the following maintenance should be carried out at least once a year - or more frequently, depending upon the demands imposed upon the equipment:

- all moving parts and all locking points of the fastening system should be greased and tested to ensure that they are functioning properly.
- only cleaning materials which do not have an adverse effect upon the anti-corrosion treatment on the components of the fitting should be used.

Work on the fastening systems and on the associated components of the fitting, or replacement of components, should be carried out by specialist enterprises only.

5. Obligations to provide information and instruction

The following documentation is available to designers, to specialist suppliers, to processing enterprises, to clients and to users for compliance with the obligations to provide information and instruction and for maintenance work in accordance with the "Product Liability Act":

- design documentation
- catalogues
- works drawings
- maintenance and servicing instructions

In order to ensure that fastening systems for windows operate effectively:

- designers are obliged to request product information from the manufacturer and to observe that information.
- specialist suppliers are obliged to observe product information and, in particular, to request works drawings, maintenance and servicing instructions from the manufacturer and to supply these to the processing enterprises.
- processing enterprises are obliged to observe the product information and in particular to request maintenance and servicing instructions as well as operating instructions from the manufacturer and to pass these on to clients and users.

6. Use of related fittings

In terms of product information and proper use, misuse, product performance, product maintenance and obligations to provide information and instruction, the variants possible within the individual fastening systems should be treated as appropriate, depending upon the features in question.

- Designed for use on timber, PVC-U and aluminium systems with a minimum eurogroove depth of 5mm.
- Available in 20 or 22mm backsets.
- Faceplate width 16mm.
- Routing length for the gearbox is only 60mm x 9mm and if this dimension is adhered to, barbs on the gearbox grip within the routed slot.
- Fixing screws are positioned well clear of the routed slot ensuring secure fitting every time.
- An arrow on the gearbox indicates the direction of the handle when in the closed position.
- Precise design of internal components ensures a smooth and regular operation.
- A 'snap down' fixing plate retains the extensions and ensures the drive rod is held in position. These are then held in place with screws providing secure protection against any attack.
- All parts are pre-set in the open position for easy fitting. Initial operation of the handle releases the mechanism.
- Extensions feature an integral shootbolt, offering a range of throws from 13mm to 19mm.

Coating specification

RotoSil surface protection procedure has been developed by Roto for the hardware product range, based upon galvanising, chromating and an additional sealing. RotoSil enables the hardware components to appear in a smooth silver tone. The quality requirements of RAL-RG 607/3 are exceeded, also the protection effect against acids has been decisively improved. The surface protection regulations of the RAL quality assurance association in Velbert, Germany, are more than fulfilled.

Surface protection with **RotoSil** exceed the requirements of the following standards:

BS 7479 96 hours

DIN 50 021

RAL 607/3 (72 hours protection from white rust and 240 hours protection against red rust).

BS 6375 pt. 2 "Performance of Windows."

RotoSil

Smooth silver-matt finish on visible hardware components.



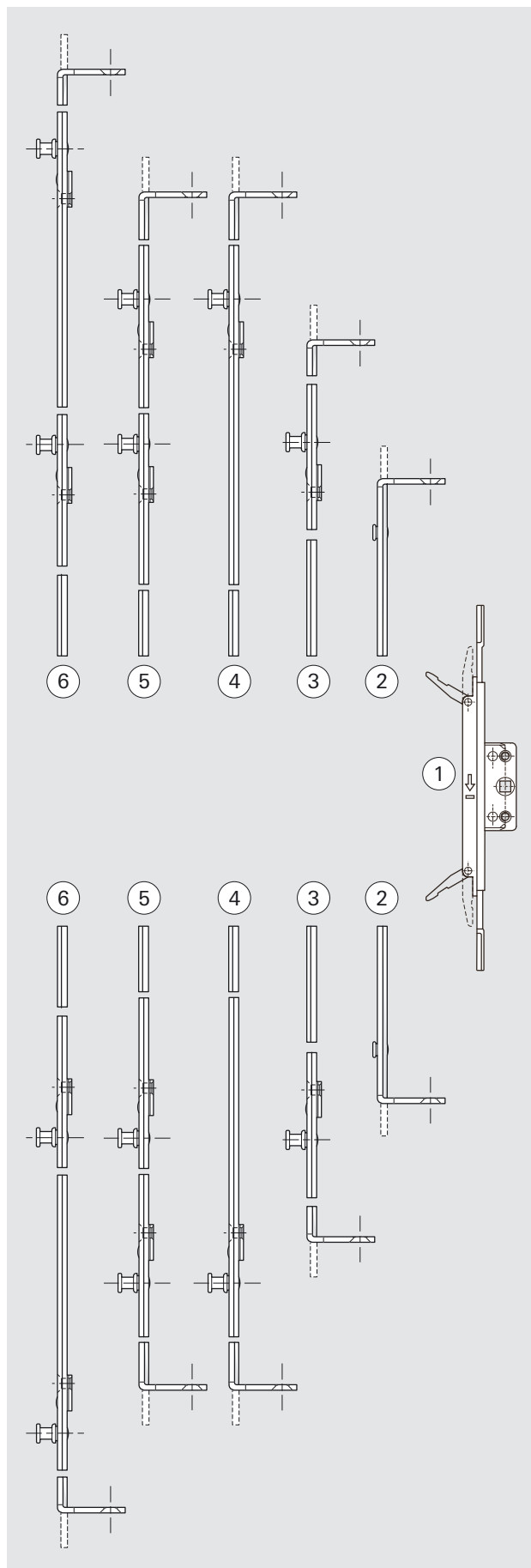

Top extensions with 8 mm high, adjustable cams

Pos.	App. Range	Faceplate	Part No.
2 (0 cams)	280 - 460 mm	160 mm	387 914
3	461 - 860 mm	360 mm	387 915
4	861 - 1260 mm	560 mm	387 916
5	861 - 1260 mm	560 mm	387 917
6	1261 - 1660 mm	760 mm	387 918

Top extensions with 9.5 mm high, adjustable cams

Pos.	App. Range	Faceplate	Part No.
2 (0 cams)	280 - 460 mm	160 mm	387 914
3	461 - 860 mm	360 mm	387 919
4	861 - 1260 mm	560 mm	387 920
5	861 - 1260 mm	560 mm	387 921
6	1261 - 1660 mm	760 mm	387 922

Gearbox

Pos.	Backset	Faceplate	Part No.
1	20 mm	140 mm	387 923
	22 mm		387 924

Bottom extensions with 8 mm high, adjustable cams

Pos.	App. Range	Faceplate	Part No.
2 (0 cams)	280 - 460 mm	160 mm	387 914
3	461 - 860 mm	360 mm	387 915
4	861 - 1260 mm	560 mm	387 916
5	861 - 1260 mm	560 mm	387 917
6	1261 - 1660 mm	760 mm	387 918

Bottom extensions with 9.5 mm high, adjustable cams

Pos.	App. Range	Faceplate	Part No.
2 (0 cams)	280 - 460 mm	160 mm	387 914
3	461 - 860 mm	360 mm	387 919
4	861 - 1260 mm	560 mm	387 920
5	861 - 1260 mm	560 mm	387 921
6	1261 - 1660 mm	760 mm	387 922

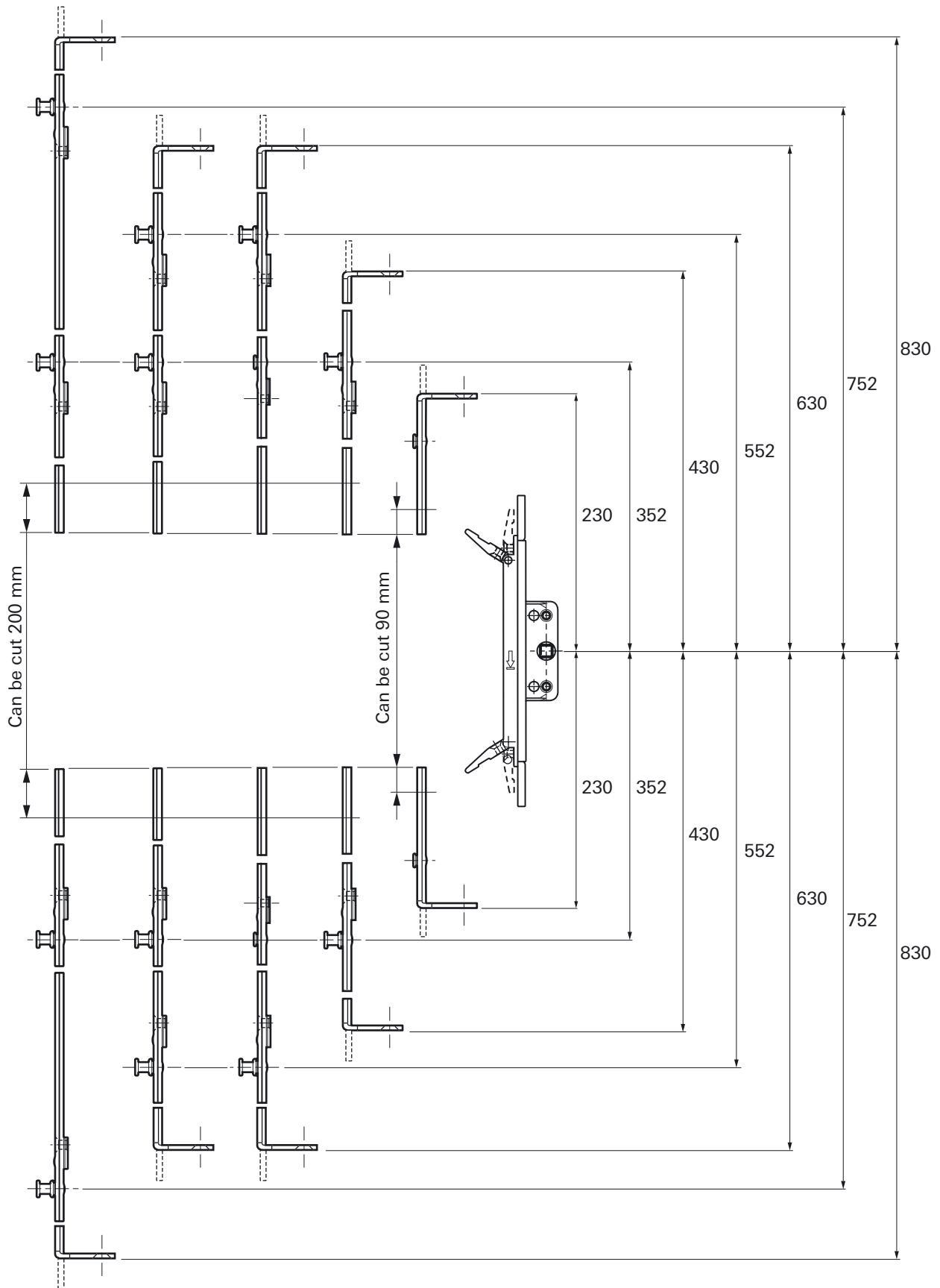

20 & 22mm backsets

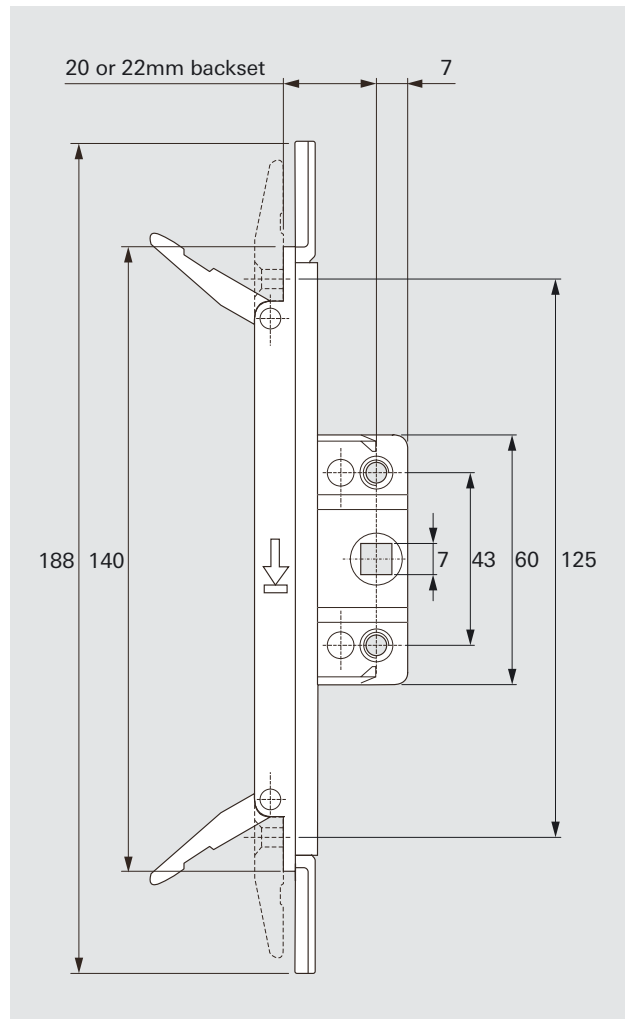

20 & 22mm backsets

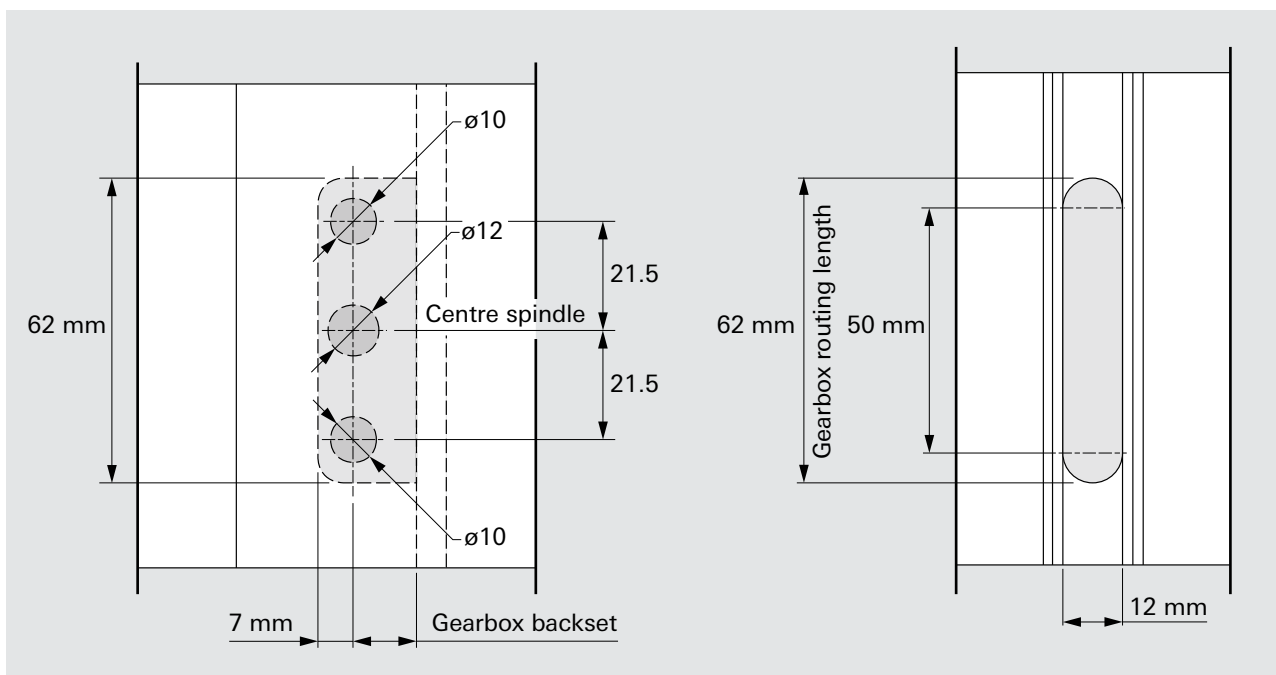

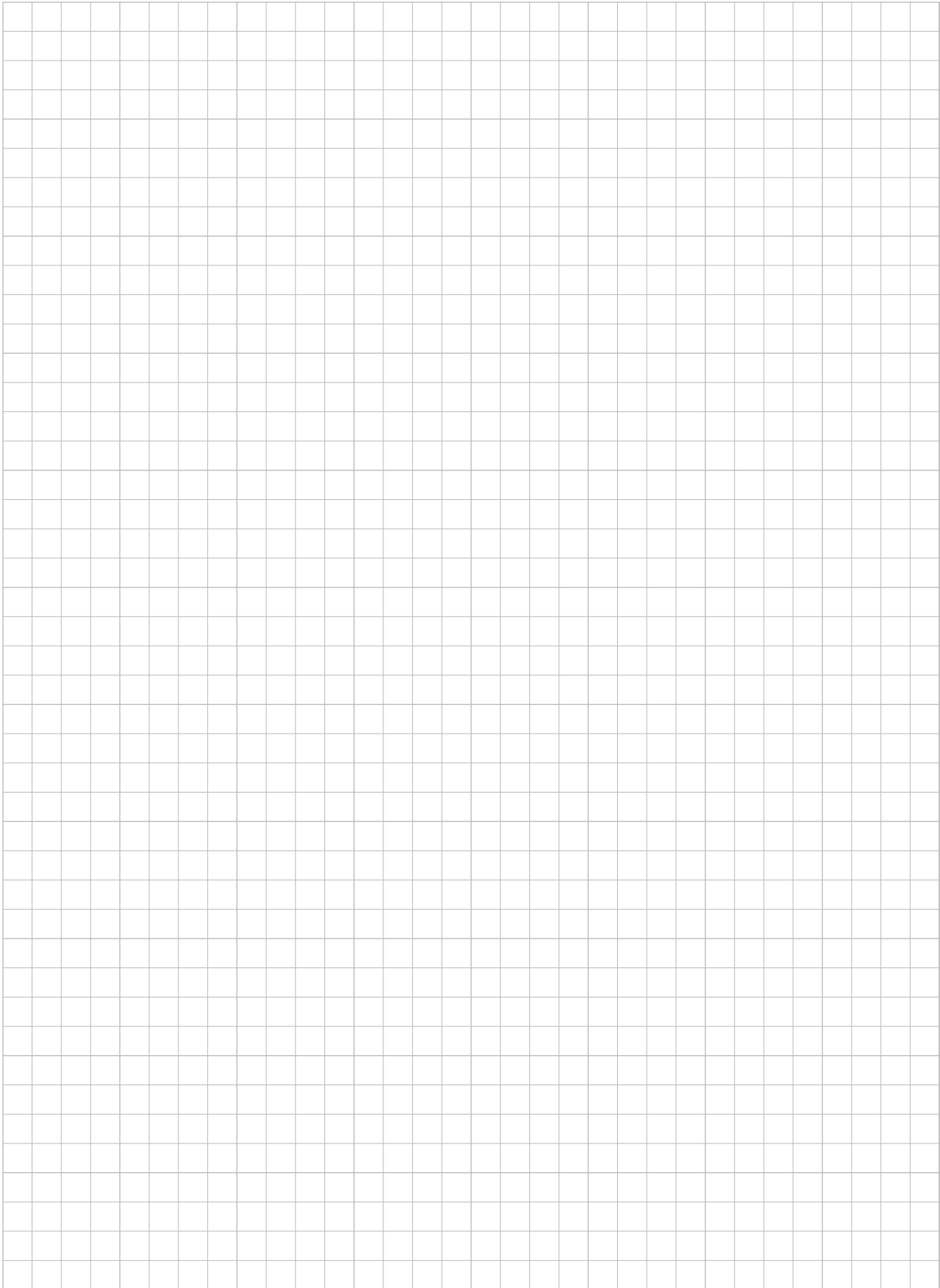

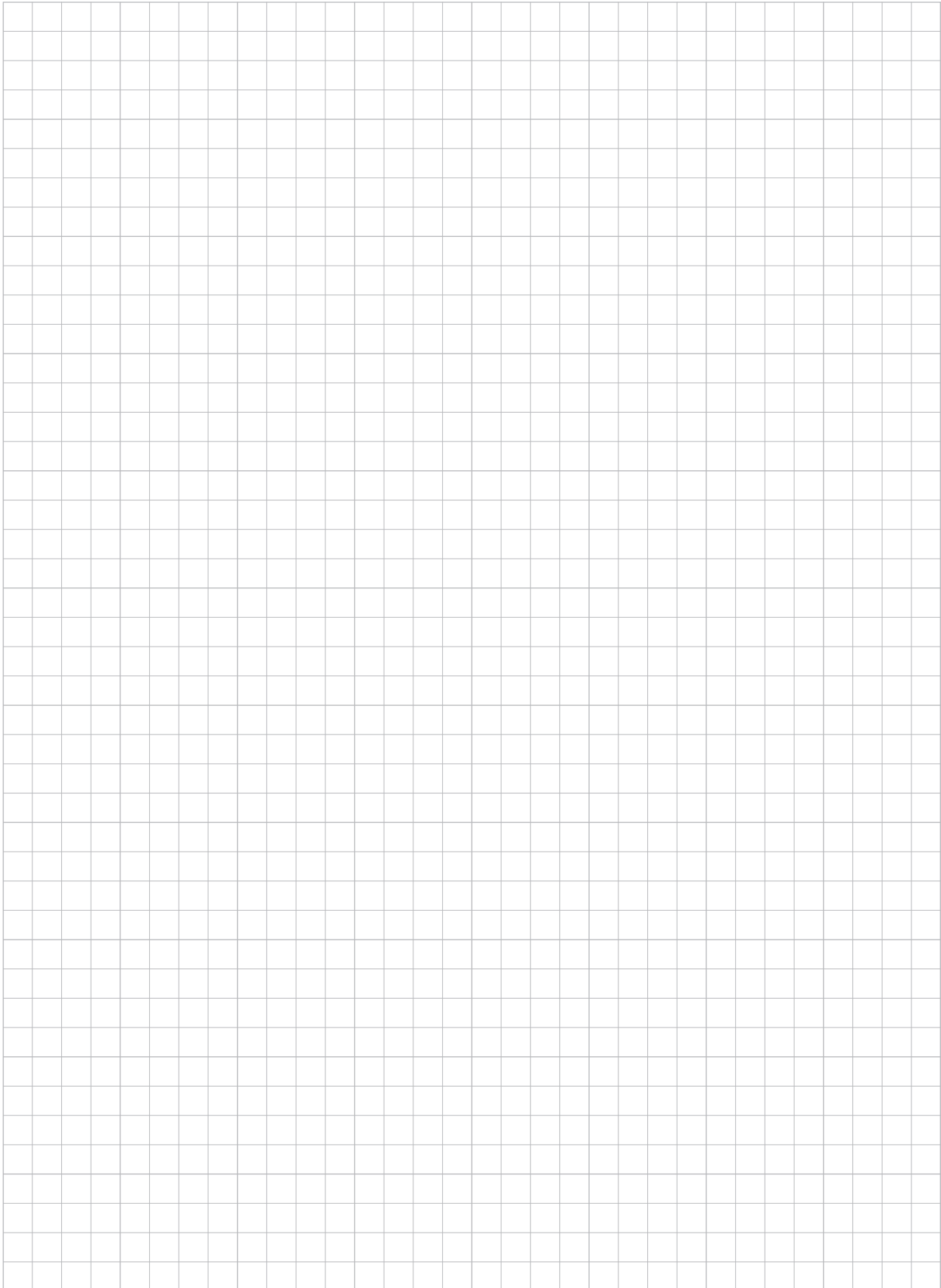

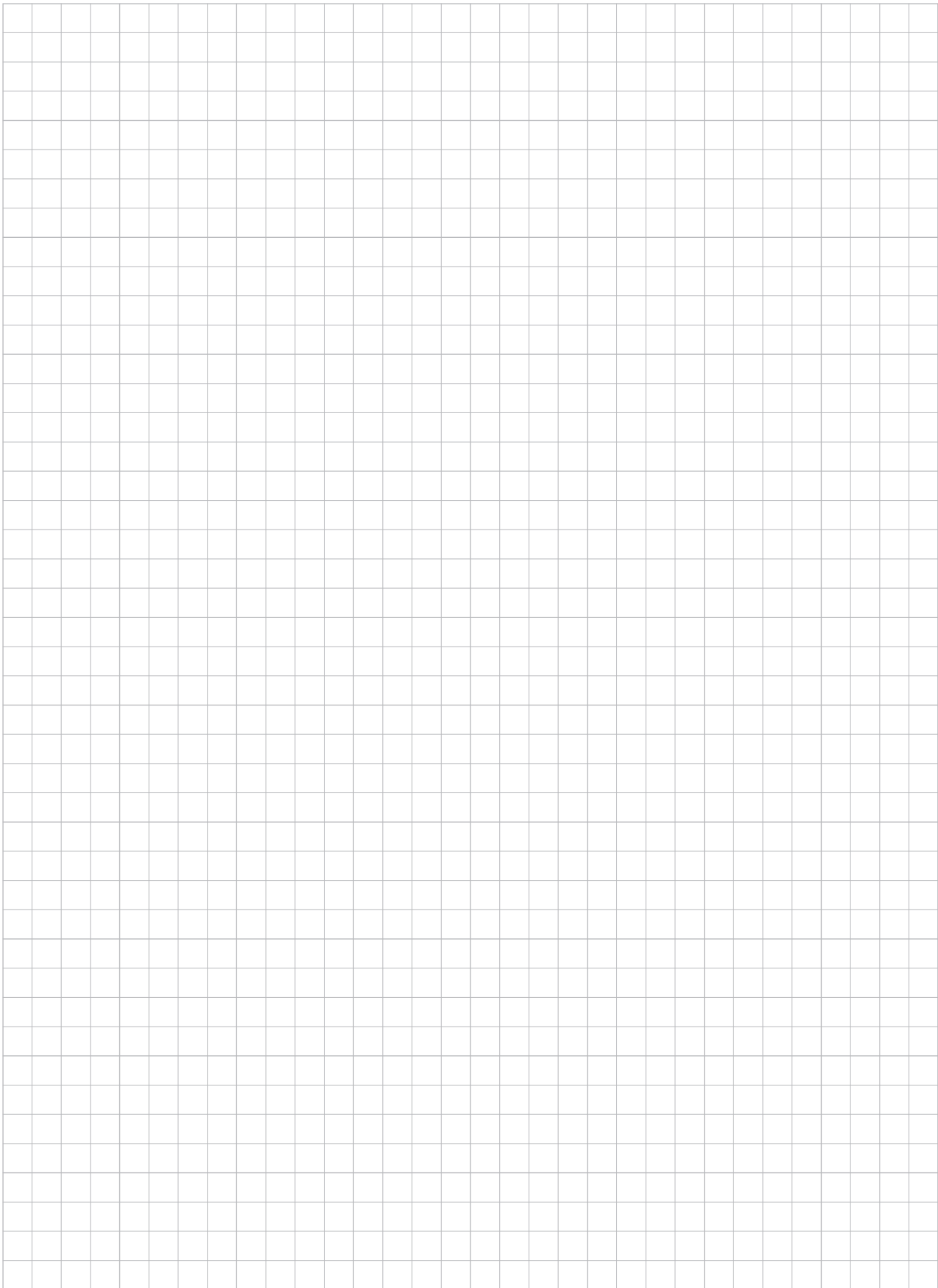



Roto Roof Windows and Hardware Ltd.

Swift Point
Rugby CV21 1QH
United Kingdom
Telephone +44 (0)1788 55 86 00
Facsimile +44 (0)1788 55 86 05
info.west@roto-frank.com
www.roto-frank.co.uk

**Roto Frank S.A.
Roto Frank Nederland**

Rue du Bosquet 1
Zoning Industriel II
1400 Nivelles
Belgique
Téléphone +32 (0)67 89 41 40
Téléfax +32 (0)67 84 14 56
info.west@roto-frank.com
www.roto-frank.com

**Roto Frank AG
Fenster- und Türtechnologie**

Stuttgarter Straße 145 – 149
D-70771 Leinfelden-Echterdingen
Telefon +49 711 7598-0
Telefax +49 711 7598-253
info@roto-frank.com
www.roto-frank.com



Interested in additional products?

Do not hesitate to ask for further information

Telephone number:
+44 (0)17 88 55 86 00